

Chapter 3. Wall Layout

- 3.1 LAYING OUT EXTERIOR WALLS
- 3.2. CREATING PLATE LAYOUT DRAWING
- 3.3 CUTTING EXTERIOR WALL PLATES
- 3.4 MARKING WINDOW AND DOOR LOCATIONS ON EXTERIOR WALL PLATES
- 3.5 MARKING STUDS ON EXTERIOR WALL PLATES
- 3.6 LAYING OUT INTERIOR WALLS
- 3.7 CUTTING INTERIOR WALL PLATES
- 3.8 MARKING DOOR LOCATIONS ON INTERIOR WALL PLATES
- 3.9 MARKING STUDS ON INTERIOR WALL PLATES

Tools needed by volunteers:

Hammer
Nail apron
Tape measure
Square
Utility knife
Pencil

Materials needed:

2x6 Plate lumber
2x4 Plate lumber
16d Nails
8d Nails
16d Duplex nails
Spray varnish

Tools and equipment needed:

Generator
Extension cord
Circular saw
Chop saw
50' Steel tape
Framing square
Red & blue chalk lines
String line
Felt tip marker

Personal Protection Equipment:

Safety glasses (required)

Reference Materials:

House Plan
Plate Layout Drawing

NOTE: All exterior and interior walls are framed 24" o.c.

Safety First! Review the Safety Checklist before performing tasks in this chapter.

3.1. LAYING OUT EXTERIOR WALLS

3.1.1. Deck Preparation

1. Before laying out any walls on the deck, clean the deck of excess dirt or glue that may interfere with chalk lines. Also, trim any decking that hangs over the edges of the deck or around the stair opening (but be sure to leave the 1¼" overhang where the top of the stairs will be attached).
2. If the house has an attached garage, see Section 23.1 for instructions on how to extend the following wall layouts onto the garage foundation.

3.1.2. Laying Out Exterior Walls On a Rectangular Deck

1. At each corner of the deck, measure in 5½" from the outside surface of the rim box from both sides of the corner. Using a square and a sharp pencil (in order to make future small corrections possible), create an initial intersecting corner mark (an "X", 1-2" in length in each direction).
2. **Create a Rectangle.** Remove the Wall Layout for Rectangular Deck Worksheet (Figure 3-1 on the next page) from this manual. With a long steel tape, "burn a foot" and measure the lengths between the initial corner marks from Step 1 above of the opposite walls at each end (see Figure 3-1). Record the measurements on the Wall Layout Worksheet. If opposite wall lengths differ by ½" OR MORE, adjust the corner marks to equalize the lengths by adding one-half the difference at each end of the shorter wall.
3. **Square the Rectangle.** With a long steel tape, "burn a foot" and carefully measure the diagonals between the corner marks to check for square. Record the measurements on the Wall Layout Worksheet. If they differ by ½" OR MORE, adjust the corner marks at EACH end of the SHORT diagonal to lengthen the LONG wall by one-half the difference. Re-check for square and adjust as needed.
4. **Check for Rim Bow.** Check all four sides of the rim box for bow. Pull a tight string line over the new corner marks at each end of the wall. Measure between the string line and the outside of the rim box every 4'-5' and record on the Wall Layout Worksheet. If the maximum measurement is greater than 5⅝", move BOTH ends of the string line equally toward the rim board until the maximum measurement is 5½". Re-mark the two corners to the new location. Continue checking the other three sides for bow and adjust corner marks as necessary. If the bow adjustment for any wall is ≥¾", re-check the rectangle for square and adjust as cited in Step 3 above.
5. Once all four corner mark adjustments have been made, carefully re-measure the precise distances between the corner marks in all directions. Adjust the marks as needed to ensure that opposing wall lengths differ by ⅛" or less. Using these final marks, snap chalk lines for all exterior wall locations. Finally, spray all chalk lines with a clear varnish to protect them from the elements.

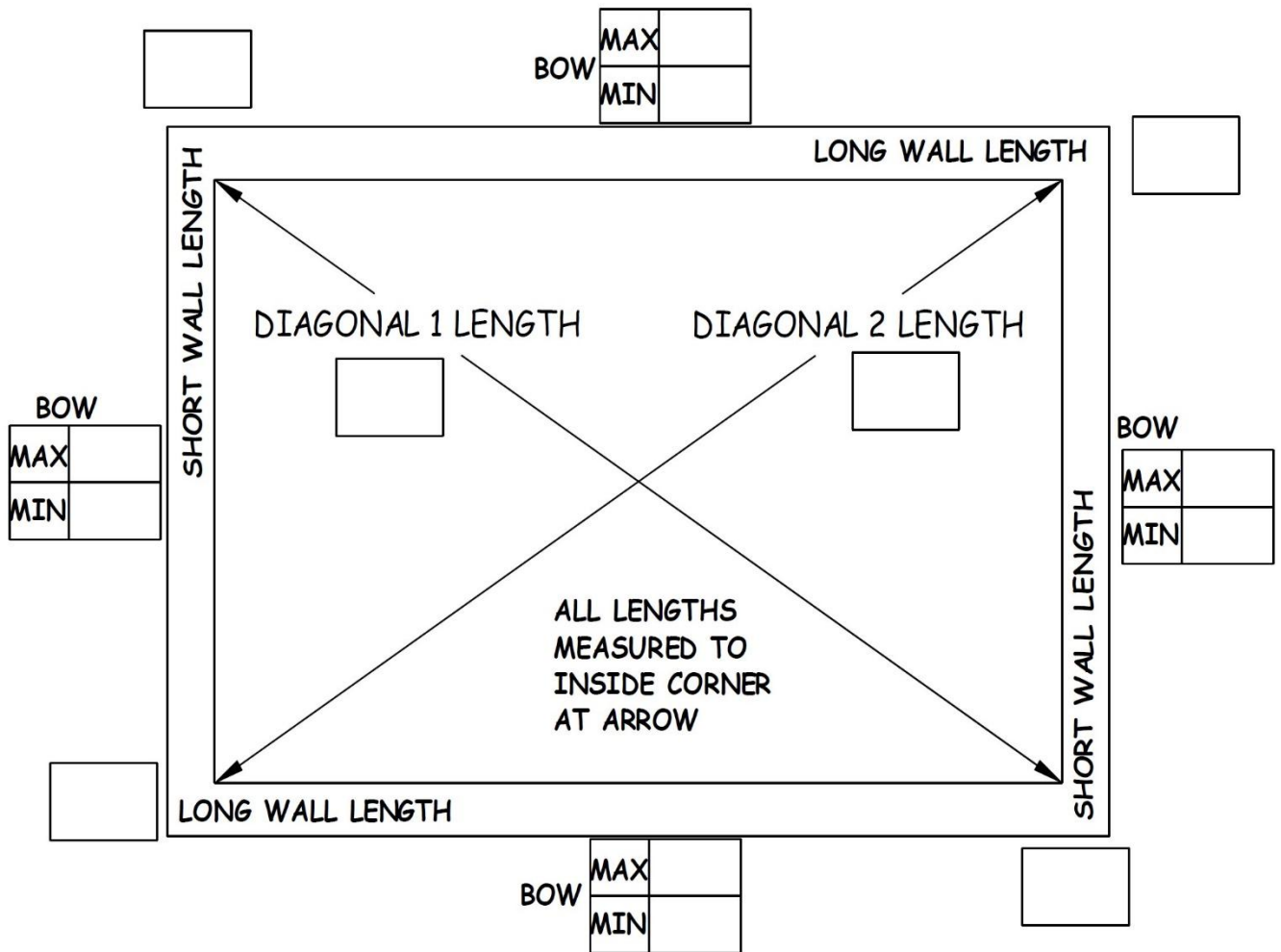

Figure 3-1. Wall Layout for Rectangular Deck Worksheet.

THIS PAGE INTENTIONALLY LEFT BLANK

3.1.3. Laying Out Exterior Walls on an L-Shaped Deck

1. **Create a Rectangle** on the main deck.
 - a. Remove the Wall Layout with Corner Porch Worksheet (Figure 3-2 on the next page) from this manual. Record any measurements made in the following steps on this worksheet.
 - b. As in Section 3.1.2.1 above, at all outside corners of the deck (Points 1, 2, 3, 5 and 6) measure in 5½" from the outside surface of the rim box, from both sides of the corner. Using a square and a sharp pencil (in order to make future small corrections possible), create an initial intersecting corner mark (an "X", 1-2" in length in each direction).
 - c. With a long steel tape, "burn a foot" and measure the distance between Points 1 and 2 (= Line 1-2) and between Points 2 and 3 (= Line 2-3). Using these measurements, locate and mark Point 4.
 - d. Drive an 8d nail into the outside of the rim box, roughly aligned with the corner marks at Points 1 and 5. In addition, drive an 8d nail into the rim board adjacent to Point 4.
 - e. Using the nails in the outside of the rim board (if desired), stretch a tight string line from Point 1, past Point 4 to Point 5, keeping the line directly over the two corner marks. If the line is not directly over Point 4, adjust both ends of the line equally, in the same direction, until it passes directly over Point 4. Re-mark corner marks at Points 1 and 5 and remove the string line.

NOTE: Any adjustment to the string at Point 5 **MUST** also keep the string aligned over Point 4. If not, adjust Points 1 and 5 equally until the string passes over Point 4.

2. **Square the Rectangle** on the main deck. With a long steel tape, "burn a foot" and carefully measure the diagonals between Points 1 and 3 and Points 2 and 4. If they differ by ⅛" OR MORE, adjust the corners as in Section 3.1.2.3.
3. **Check for Rim Bow** on the main deck. As in Sections 3.1.2.4 and 3.1.2.5, check the two side walls and the back wall for rim box bow. In each case, stretch a tight string line across each corner mark and measure from the line to the rim board every 3'-4'. If the maximum measurement is greater than 5⅝", move **BOTH** ends of the string line equally toward the rim board until the maximum measurement is 5½". Re-mark the corner marks to the new location. If the bow adjustment for any wall is ≥⅝", re-check the rectangle for square and adjust as described in Step 2 above.

THIS PAGE INTENTIONALLY LEFT BLANK

THIS PAGE INTENTIONALLY LEFT BLANK

4. **Adjust Front Deck Extension**

- a. Using nails on the outside of the deck if necessary, stretch a tight string line from Point 3 to Point 4. Measure Line 5-6 and use this measurement to locate Point 7 on Line 3-4. Mark the deck with an X.
 - b. Measure Line 4-5 and Line 6-7. If not equal, adjust either Point 5 or Point 6 to ensure that Line 5-6 is parallel with Line 3-4.
 - c. In a similar manner, measure Lines 5-6 and 4-7. If not equal, adjust Point 6 or Point 7 to ensure that Line 6-7 is parallel with Line 1-5.
 - d. Check Lines 5-6, 6-7, and 3-7 for bow (max 5⁵/₈"") from the outside of the rim board. If necessary, move the end points of each line (3-4, 5-6, or 6-7) toward the rim board as in Step 3 above.
5. As in Section 3.1.2.5, carefully measure the precise distances between corner marks in all directions. Adjust the marks as needed to ensure that opposing wall lengths differ by 1/8" or less. Snap the lines for all exterior wall locations. Spray all chalk lines with a clear varnish to protect them from the elements.

NOTE: Snap continuous chalk lines from Point 3 over Point 7 to Point 4 and from Point 1 over Point 4 to Point 5.

3.2. **CREATING A PLATE LAYOUT DRAWING**

1. The Plate Layout Drawing, a 24"x36" printed layout (typically mounted on 1/8" plywood) of the main floor deck showing both exterior and interior walls, depicts all full-length plates and any pre-defined plate lengths (see Figure 3-3). The Drawing is usually created offsite prior to the build day and stored in the construction trailer. If the drawing is not found onsite, create one using the following steps.
2. Obtain a printed copy of the main floor deck. Alongside the exterior walls on the print, sketch in lines representing the recommended lengths of upper and bottom plates to be cut and placed in that location. Rather than cutting every piece to length, use factory-length pieces wherever possible. Specify these uncut pieces with "+/-" to designate the actual dimensions are not exact. Factory pieces should be limited to 10', 12', 14', and 16' lengths.
3. **Bottom Plate Layout.** Starting at the zero corner, mark first along the long wall the successive locations of all pieces, both factory and field cut. The ends of all plates must fall between studs or inside a door opening (where it will be cut out). NEVER locate the end of a plate under the location of a single stud. Where factory length pieces do not fit, reduce the length of the piece so that the end falls at the desired location. The final piece needed to reach the corner will be field cut, so its length is not specified on the Drawing. Repeat this procedure for all remaining walls.

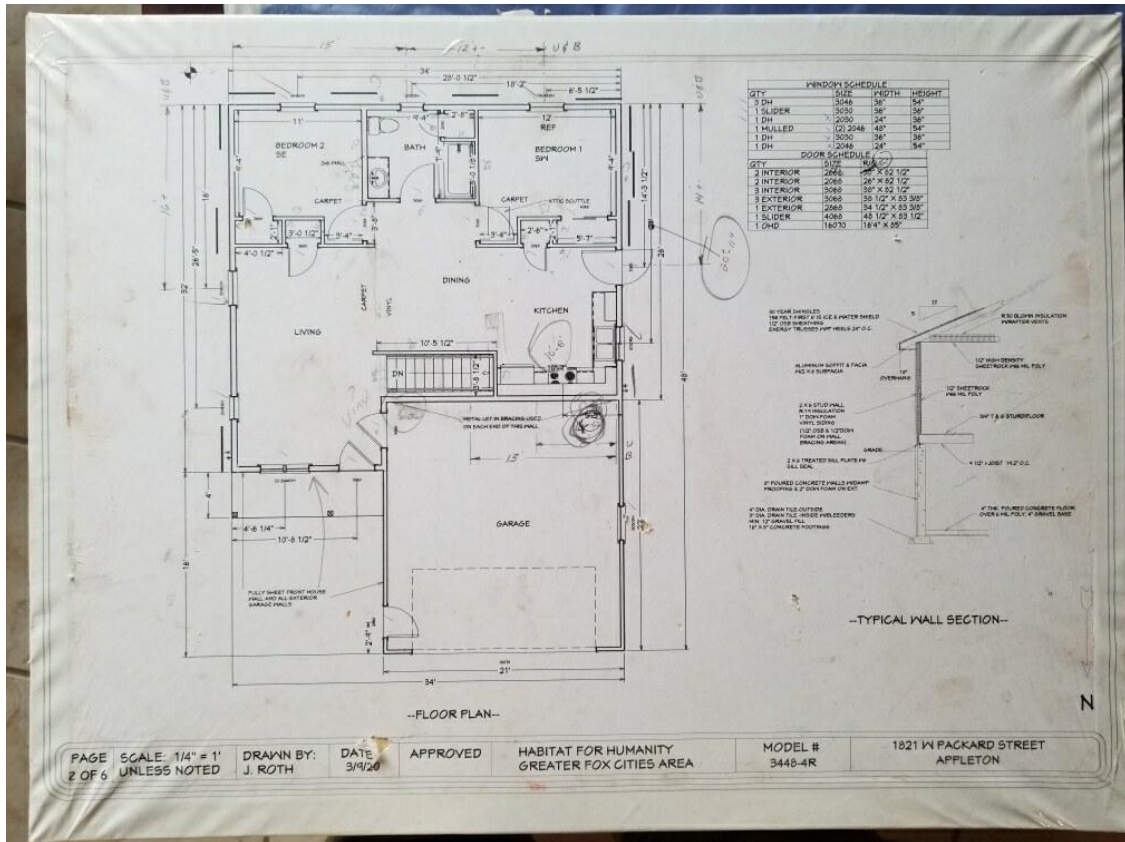

Figure 3-3. Plate Layout Drawing.

4. For plates on the long walls, the studs are placed on 2' centers from the outside of the zero corner. Therefore, plates on the short walls will be cut $5\frac{1}{2}$ " shorter than that to place their ends inside the long wall plates (see Figure 3-4).

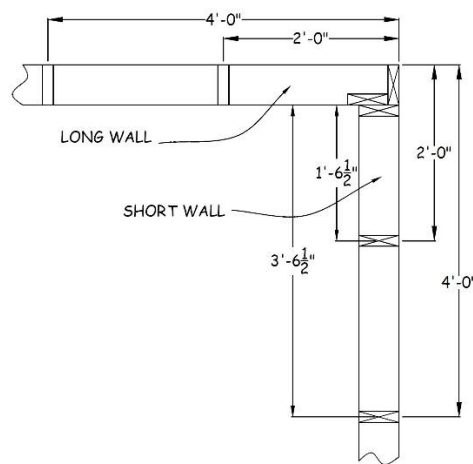

Figure 3-4. Corner Layout.

5. **Upper Plate Layout.** Again, starting at the zero corner, mark along the long wall the successive locations of all pieces, using factory length pieces as much as possible.

Select lengths that end on a window or door header. If possible, match upper and bottom factory lengths at the same location. Where factory length pieces do not fit, reduce the length of the piece so that the end falls directly on a stud center (a last resort). The final piece needed to reach the corner will be field cut, so its length is not specified on the Drawing. Repeat this procedure for the remaining walls.

3.3. CUTTING EXTERIOR WALL PLATES

1. Before cutting the wall plates, consult the Plate Layout Drawing typically located in the construction trailer. If the Plate Layout Drawing is not found on the worksite, create one following the instructions in Section 3.2 above.
2. Identify any 2x6 lumber 18'-20' in length. Set aside at least four of the straightest for gable end preparation (ladder/outlook outside pieces). Wrap the pieces with shrink wrap and label (with red crayon) "Gable end use only".
3. Some plate lengths are shown with a (+/-) designation on the Plate Layout Drawing. This means that a standard-length 2x6 can be used without cutting. Other pieces are shown with an exact length. They should be cut precisely to that length.
4. Starting at the zero end of a long wall, lay one end of the upper and bottom wall plates 5½" past the short-wall chalk line. Then continue laying out additional plates as shown by the hand-drawn lengths on the Plate Layout Drawing.

NOTE: The chalk line of the two short walls may not be exactly 5½" from the outside of the sill box. Therefore, ALWAYS use these lines as reference in placing and cutting long wall plates rather than the outside of the sill box. Also, be sure to use lumber with good, clean, and square edges at each end of the wall plates. The outside corners at these ends will be used to precisely measure wall diagonals while squaring the assembled wall on the deck (see Section 5.2.2).

5. For the last plate of each wall, the length is not typically specified because of possible differences between the House Plan and actual deck size. Field cut these pieces to fit using the short wall chalk line and adding the additional 5½". Before measuring, be sure the first plate is still in the correct position and all plate joints are tight.
6. Mark the inside edge of the bottom plate 5½" from each end of the plate to aid in setting these walls in the correct position during wall building. These lines should align with the short wall chalk lines.
7. Finally, tack the upper and bottom plates together with 16d duplex nails and set in location on the deck.
8. Repeat the above for the opposite long wall.
9. For the short walls, again consult the Plate Layout Drawing to identify full length and pre-defined plate lengths.

- a. Set the first set of plates in place on the deck with one end (per the House Plan) located precisely on the long wall chalk line at the corner. Cut and place any mid-wall plates and butt tightly with the first plates. Tack with 16d duplex nails to hold in place.
 - b. Measure to the opposite long wall chalk line and field cut these pieces to fit.
 - c. Again, butt the pieces tightly and tack with duplex nails.
 - d. Repeat with the opposite short wall
10. After both sets of opposing walls are complete, recheck to be sure their lengths are equal and that ends match their respective chalk lines. If lengths differ by more than $\frac{1}{8}$ " , trim the long set of plates or move the location of the end stud of the short set (on the non-zero end) past the end of the plates (e.g., if the wall is $\frac{1}{8}$ " short, then mark the end stud at $1\frac{3}{8}$ " from the end instead of the typical $1\frac{1}{2}$ "; label that mark with "Do Not Move").

3.4. MARKING WINDOW AND DOOR LOCATIONS ON EXTERIOR WALL PLATES

1. Starting at the zero end, lay out the long walls first (see the House Plan to identify the zero end). Stand the plates with their outside edges facing up and make layout marks on these edges. Hook a tape to the zero end of the plates and mark the center-line location of all windows and doors using a short VERTICAL line overlaid with a "C" and an "L", to create a mark for center line (Ⓢ). Also, label the outside edges of both upper and bottom plates with the window and door size shown on the Plate Layout Drawing (e.g., 3040 Window or 3068 Door).

NOTE: When laying out the location of the exterior doors, take special note of the location of the porch slabs and adjacent walls. The door King studs must be at least 3" from an adjacent wall to allow for trim. Verify with the Construction Supervisor where the door should be located relative to the porch center

2. When laying out the short walls that intersect the long walls, again start at the zero end but this time extend the tape measure $5\frac{1}{2}$ " beyond the end of the plate. This offset takes into account the $5\frac{1}{2}$ " width of the intersecting long wall plate during layout.

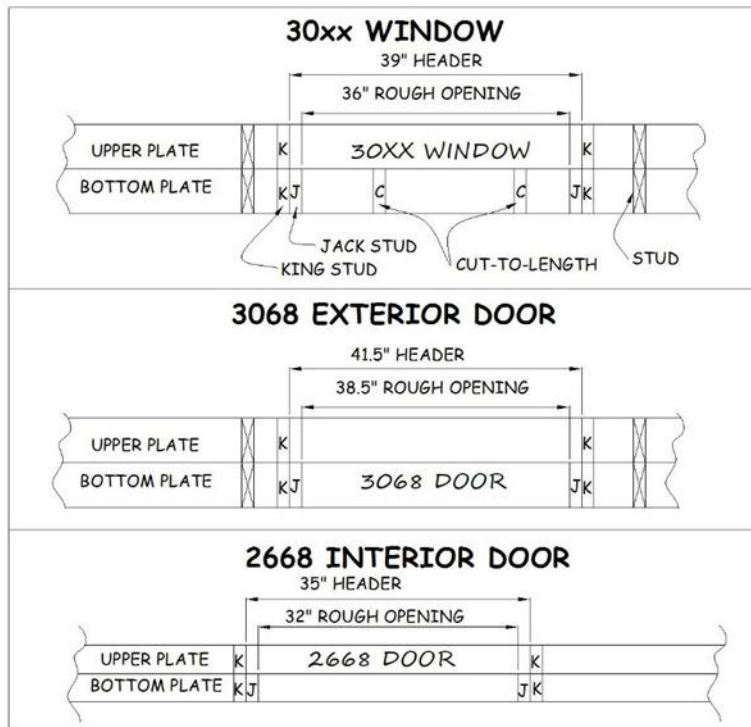

Figure 3-5. Plate Marking for Doors and Windows.

3. Referring to the window or door sizes indicated on the Plate Layout Drawing, measure and mark the location of the King and Jack studs supporting the header (see Figure 3-5). Window and door sizes are indicated with a four-digit code. The first two digits represent the width of the opening in feet and inches. The second two digits represent the height of the opening in feet and inches. For example, a 3040 window is 3'-0" wide by 4'-0" high (i.e., 36" wide by 48" high).

- a. The "rough opening" for all windows equals the width of the window.

EXAMPLE: The rough opening for a 3640 window is 3'-6" = 42".

- b. The "rough opening" for all exterior doors is 2½" wider than the door size.

EXAMPLE: The rough opening of a 3068 door is 3'-0" + 2½" = 38½".

4. Label the King and Jack stud locations with "K" or "J" to specify the location of the pre-built window and door components during wall assembly. The Jack studs will always be to the inside of the King Studs. Stud width is always 1½". Label the location of both King and Jack studs on the bottom plate but label only the King stud on the upper plate (see Figure 3-5).

REQUIREMENT: Any opening 6' or wider requires two Jack studs under each end of the header. Therefore, the header will be a total of 6" wider than the rough opening rather than the typical 3" used with windows and interior doors.

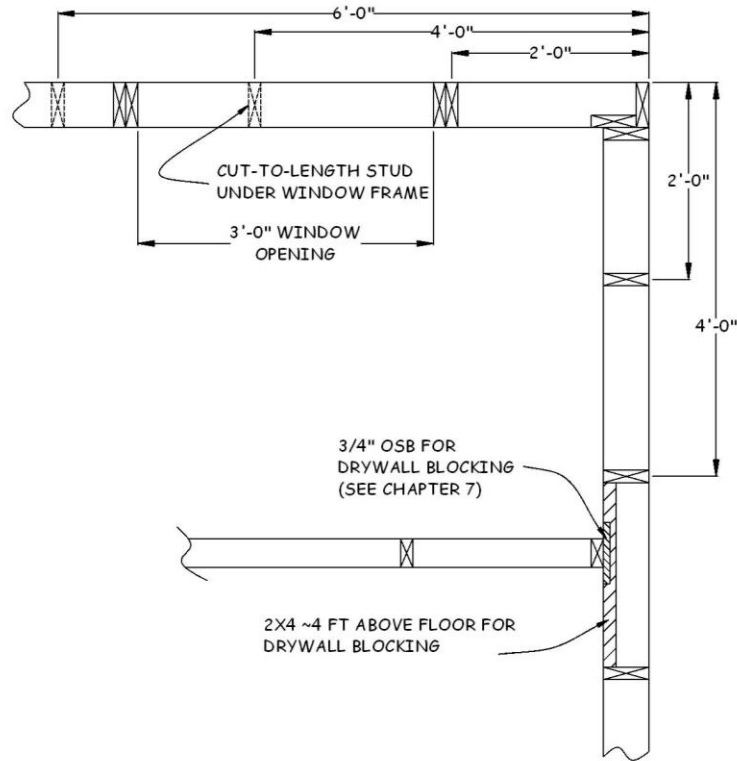

Figure 3-6. Stud and Blocking Layout.

3.5. MARKING STUDS ON EXTERIOR WALL PLATES

1. Layout long walls first. Before marking stud locations, check opposite walls to be sure they are the same length (within $\frac{1}{8}$ "). If not, trim to equalize.

NOTE: The stud layout step is very important with 24" o.c. framing because it ensures the studs are located directly under roof trusses. This configuration, known as stacked framing, is needed to transfer load from the roof trusses (per code).

2. Starting at the zero end, hook the measuring tape on the end of the plates and mark the location of all wall studs on 24" centers. Center the stud marking jig on these center marks, mark both edges of each stud, and place an "X" within the two edge marks. If the stud marking jig is not available, use the tape measure to mark the stud edges $\frac{3}{4}$ " on either side of the center mark. In general, if using the 50-ft steel tape, do not hook the tape at the end of the plate; burn 24" and mark after that.

NOTE: By design, some stud locations will coincide with a window or door King stud. In these instances, leave the "K" designation already marked on the plates. If the "K" location is not on-center, it may need to be moved or alternatively by locating an additional stud at that location (see the Construction Supervisor).

3. Wherever 24" centers fall within a window, mark an "SX" on the bottom plate to represent a short stud under the window. Do not mark a stud within a door opening.
4. If the length of the long walls is not a multiple of 24", it may be necessary to add an extra stud centered 48" from the non-zero end of the wall to accommodate a full sheet of OSB wall sheathing at that end.
 - a. If the length is long by $\frac{3}{4}$ " or less, ignore the difference.
 - b. If greater than $\frac{3}{4}$ ", measure back from the non-zero end of the plates and center the extra stud at 48". If this overlaps the existing 24" o.c. stud, locate the extra stud tight to the non-zero side of that stud. (During wall building, they will be nailed together.)
 - c. If the extra stud does not contact or overlap the existing 24" o.c. stud, center the extra stud 48" from the end. (During wall building, the gap between the two studs will be filled with foamboard and the "sandwich" will be nailed or screwed tightly together.)
 - d. If the House Plan does not show OSB sheathing at the wall end, or if a window or door prevents installation of a full 48" wide sheet, see the Construction Supervisor.

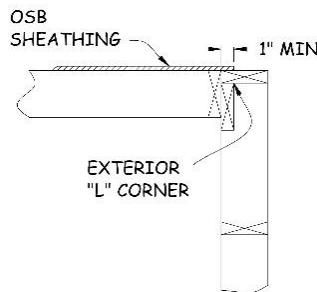

Figure 3-7. Exterior L-Corner.

5. At each end of the long walls, layout an L-corner with two 2x6 studs made up of the normal 2x6 end stud plus an extra 2x6 stud perpendicular to the end stud on the interior side of the wall (see Figure 3-7). Mark the "L" as "Corner Down" to specify that the extra 2x6 will lay face down on the deck as the wall is being built. This will place the existing 2x6 stud facing the end of the adjoining short wall forming an inside corner.

NOTE: As a general rule, outside corners are configured as "Corner Down" and inside corners are configured as "Corner Up."

6. After marking the long walls, mark the stud locations on the short walls. Starting at the zero end, extend the tape measure $5\frac{1}{2}$ " beyond the end of the plates and mark the stud locations on 24" centers. Place "X's" and "SX's" as appropriate. In addition, locate a stud at each end of these walls.

7. At the non-zero end of the short walls, again extend the tape 5½” past the end of the plate and measure back 48”.
8. If there is no stud centered at that location, proceed as follows:
 - a. Keeping the end of the tape 5½” past the end of the short wall plates, determine if any stud is centered between 48” and 52½” from the outside corner. If a stud is located within that span, the inside edge of the OSB will be nailed to that stud during wall building and the outside edge will be nailed to the long wall L-corner.
 - b. If a stud is not centered between 48” to 52½” add a stud at 48”.
9. For homes with an attached garage, continue laying out stud locations per Figure 3-8.

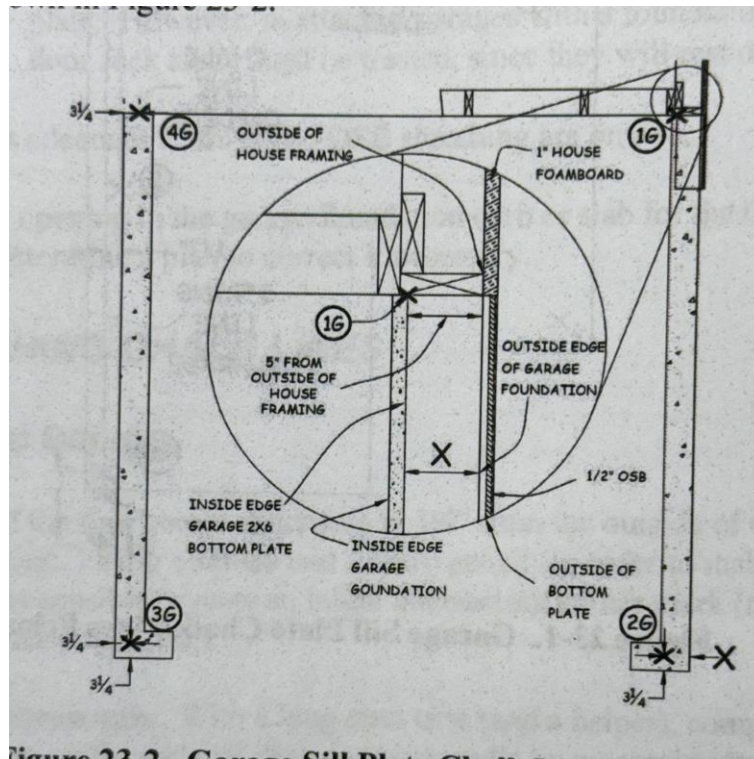

Figure 3-8. Continuing Wall Layout to Attached Garage.

10. For each wall section:
 - a. Mark the inside edge of the upper plate with “UPPER” and the inside edge of the bottom plate with “BOTTOM” (see Figure 3-5). Mark the upper plate with a letter and arrow showing the compass orientation (north, south, east or west) of the plates while lying on the deck (see Figure 3-9).
 - b. If not already done, make a mark on the inside edge of the **long wall** bottom plate 5½” from each end of the plate. This mark will help to align the ends of the wall with adjoining walls while it is being erected.

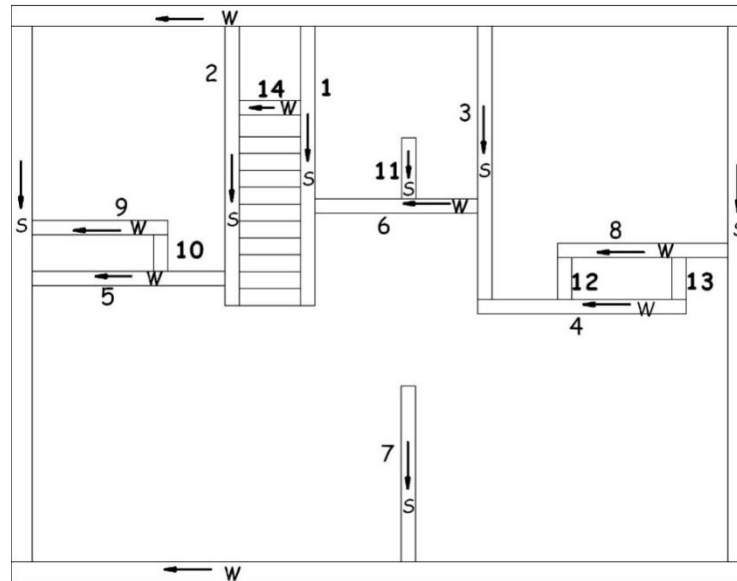

Figure 3-9. Plate Labeling Diagram.

11. Check the Plate Layout Drawing and/or deck for any intersecting 2x4 or 2x6 walls. At these locations, mark the top edges of the plates with lines 3½” or 5½” apart, as appropriate, and mark a “W” between these lines. This will aid in locating the intersecting walls during wall building.

3.6. LAYING OUT INTERIOR WALLS

1. Referring to the House Plan, lay out the location of all interior walls, snapping chalk lines for each side of the interior walls. The location of walls labeled “Ref” may not exactly match the House Plan owing to foundation differences. All interior walls that intersect an exterior wall are measured from the inside of the exterior wall.

REQUIREMENT: Bath tub/shower rough opening must be exactly 60⅛” (for a 5’ tub unit) to leave extra space to install the tub.

2. Start by laying out the walls around the stairway opening since these provide reference points for several other walls. Regardless of whether the House Plan calls for a door at the top of the stairs, extend these walls 5” beyond the lip of the stairway opening.
3. Check the House Plan for a special 2x6 interior “plumbing wall”. (If present, this wall is wider to accommodate plumbing from the basement to the attic and is typically laid out in one of the following two configurations:
 - a. A simple 2x6 extension of a 2x4 interior wall: Lay out the full wall simply as a 2x6 wall section abutting a 2x4 section, noting which side is the flush side per the House Plan.
 - b. A 2x6 sliding closet wall intersecting a 2x4 wall at 90°: The intersection of the closet wall framing with the 2x4 interior wall requires a special header

configuration (see Figure 3-10). If the two walls create an “L”, butt the side of the 2x6 wall against the end of the 2x4 wall (this makes the 2x6 wall the “long” or overlapping wall). If they create a “T” (where the 2x6 wall butts up to the 2x4 wall), extend the closet header into the 2x4 wall. In both cases, lay out the Jack stud flush with the closet side of the 2x4 wall. Adjoining that will be the King stud and ½” of OSB, creating a 3½”-wide block equal in width to the 2x4 interior wall.

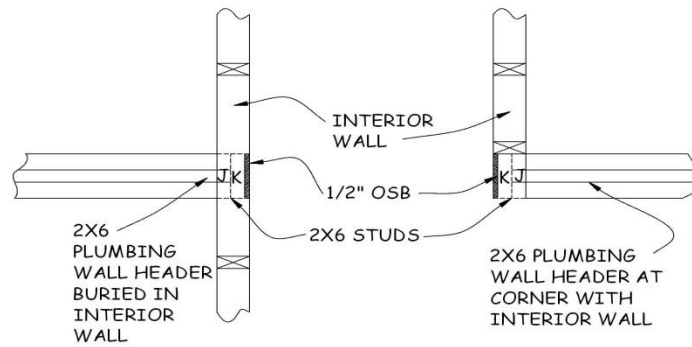

Figure 3-10. Plumbing Wall Configuration.

- Referring to the House Plan, check for flush sliding closet walls that end at an inside corner of the closet (typically adjoining the 25” closet end wall). Similar to a plumbing wall, lay out the end of the flush sliding wall with a 3½” sandwich of Jack stud, King stud, and ½” of OSB (see Figure 3-11).

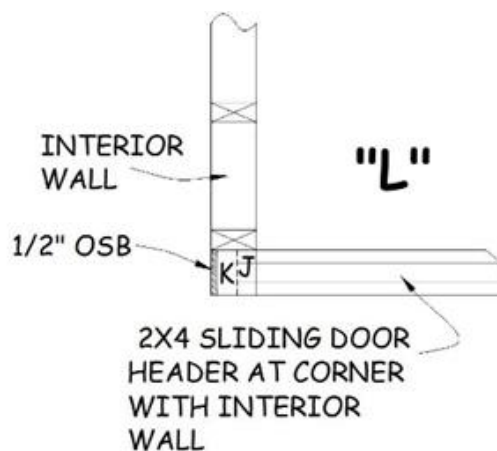

Figure 3-11. Interior L-Corner in Flush Sliding Door.

- At corners and intersections, pay attention to whether a door will be built at that location. If so, make the room wall long and the door wall short, not the other way around. Include an “L-Corner” at the door end of the room wall and lay out the door plates so that the KJ pair abuts the L-Corner (see Figure 3-12). This allows for easy nailing through the “L” into the King stud. This configuration also provides a stronger corner that does not depend on nailing one stud into the edge of another stud. In

addition, nailing the end of the long wall to the floor provides a stronger anchor than does toenailing the KJ pair to the floor.

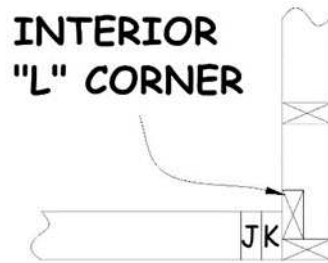

Figure 3-12. Interior L-Corner Configuration.

6. Referring to the House Plan, locate walls of unusual height:
 - a. For a 42" height wall, label the DECK with '42" WALL/39" STUDS'.
 - b. Mark the wall with the full wall length, including the 3½" x 3½" end post (see Figure 3-13).

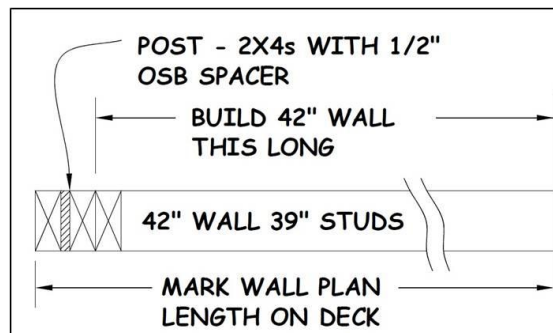

Figure 3-13. Marking Wall Plan on Deck.

- c. For a wall that is a COMBINATION of full-height and 42"-height, mark the location of the joint between the two sections ON THE DECK to ensure that two separate upper plates will be cut.
 - d. For any wall at the end of the stairway opening in the deck (where a platform would be built) label the DECK with '13¾" WALL/10¾" STUDS'.
7. Spray all chalk lines with clear varnish to protect them from the elements.

3.7. CUTTING INTERIOR WALL PLATES

1. Cut upper and bottom plates to match the layout on the deck. Tack the upper and bottom plates together with duplex nails and set in location on the deck
2. Recheck wall intersections to determine which wall end should abut the side of the other wall (which wall will be the “long” wall and which will be the “short” wall). This may be dictated by an adjoining door. (See Section 3.6.5 and Figure 3-12 above.)

NOTE: All closet side walls are typically the “short” wall in the layout (typically 25” long)

3. On walls that require multiple upper and bottom plates (or have a joint), stagger the upper and bottom plates by placing the upper and bottom plates at opposite ends of the wall and join at the top and bottom of separate studs (the joint between upper plates must be centered on a stud, not located above a door).
4. For any 42”-height walls, label the upper and bottom plates with ‘42” WALL/39” STUDS’. For any short wall that supports the closet platform above the stairway, label the plates with ‘13¾” WALL/10¾” STUDS’.
5. On walls that include both full-height and 42”-height sections cut separate upper plates for each section. Cut the bottom plate to span the joint.
6. If the wall will include a 3½” x 3½” full-height post at the end of the 42”-height section, cut the upper plate of the 42”-height section 1½” short to accommodate the post.
7. If a full-height post is not planned at the end of the 42”-height section, cut the bottom plate 1½” short. This will accommodate alternative methods for anchoring the end of the wall to the deck.

3.8. MARKING DOOR LOCATIONS ON INTERIOR WALL PLATES

1. Referring to the House Plan and the Table of Door Measurements (Table 3-1), begin by locating and marking the door centerlines using a short VERTICAL line. Overlay that mark with a “C” and an “L” to create a mark for center line: CL . Continue to mark the King Stud/Jack Stud pairs on the wall plates.

NOTE: The separation between Jack studs (the “rough opening”) for all swinging interior doors is 2” wider than the door width stated on the House Plan. For all sliding doors, the rough opening is ½” wider than the door stated door width. (See dimensions in Table 3-1.)

2. Mark the location of each door and label with the door size and type (e.g., 4068 Slider).
 - a. For bedroom and bathroom doors, locations may need to be adjusted so the hinge-side King/Jack stud pair is abutted to the adjoining wall. This places the hinge

side at the corner for proper door swing and still allows room for door trim. (See Section 3.9.1.c for special stud location for these intersections.)

- b. For SWINGING closet doors (except those at the platform end of the stairway opening) and non-flush sliding doors, locate the centerlines per the House Plan. Measure, locate, and mark the King and Jack studs as detailed in Table 3-1.

NOTE: For the closet door at the platform end of the stairway opening, locate the outside edge of the King stud flush with the outside edge of the platform short wall. This will allow room in the closet at the latch side of the door for closet shelving.

- c. For FLUSH sliding doors, locate the inside of the single King/Jack stud pair the specified rough opening distance from the exterior wall (see Table 3-1), e.g., 60½” from the wall for a 5068 door.

NOTE: Ignore what appears to be a small wall section on the house plan next to the exterior wall. This is an artifact of the CAD software and does not represent an actual wall section. The end of the header will actually be supported inside the exterior wall.

Table 3-1. Examples of Interior Door Measurements – Main Floor.

Interior Door Type	Rough Opening Width	Header Length	Jack Stud Length
36” Swinging Door	38”	41”	81”
60” Sliding Door	60½”	63½”	82”
60” Bifold Door	61½”	64½”	80”

3.9. MARKING STUDS ON INTERIOR WALL PLATES

1. Lay out studs on 24” centers on upper and bottom plates.
 - a. If the wall intersects an exterior wall, start layout from exterior wall end. (Sheetrocking of interior walls will occur first and will start from exterior walls).
 - b. If the wall intersects only an interior wall, start layout to match likely sheetrock installation.
 - c. Where a door will be attached at the end of a bathroom or bedroom wall, mark the end of the wall for a 2x4 L-corner oriented to allow nailing through the L-corner into the King stud of the door (see Figure 3-12). This is similar to the 2x6 L-corners used in the exterior walls.
 - d. Locate the plates labeled ‘13¾” WALL/10¾” STUDS’ and layout two end studs and one interior stud 24” o.c. (see Figure 3-14 and Section 6.4).

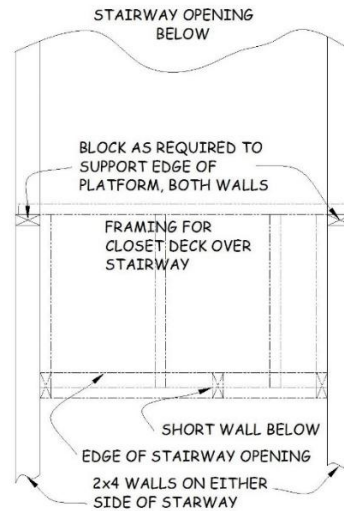

Figure 3-14. Stud Layout Around Stairway Opening.

2. For walls adjoining the stairway opening, one wall typically includes a sliding closet door next to the exterior wall. This closet usually includes a platform over the bottom of the stairs.
 - a. If this is so, layout the wall opposite the closet as usual, starting at the exterior wall.
 - b. On the closet side, layout the closet KJ studs and then continue laying out wall studs on the same centers as the opposite wall.
3. For walls adjoining the tub/shower:
 - a. The short wall next to the tub/shower will typically be 36" long. As usual, layout studs on 24" centers starting at the intersecting wall. At the opposite end, layout a 2x4-2x6 L-corner similar to that shown in Figure 3-11, with the 2x6 base of the L on the surface facing the tub. This will provide vertical blocking to which the shower flange can be attached, 31½" from the wall.
 - b. On the opposite wall, layout a similar L-corner. Center the L, with the 2x6 base facing the tub, directly opposite the L-corner on the short wall.
4. As with exterior wall plates (see Section 3.5 above), on the top edges of the interior wall plates, mark the location of any intersecting walls with lines and a large "W" between the lines to aid in locating the intersecting wall during wall building.
5. When complete, label upper and bottom plates. Mark compass orientation and label both plates and deck with an identifying number (see Figure 3-8).