

Chapter 6. Porch, Stairway and Basement Walls

6.1 FRAMING PORCH

6.2 FRAMING BASEMENT WALLS

6.3 CUTTING ANGLE STAIRWAY WALL

6.4 FRAMING STAIRWAY CLOSET PLATFORM

6.5 FRAMING STAIRWAY CABINET OPENING

Tools needed by volunteers:

Hammer
Nail apron
Tape measure
Square
Utility knife
Pencil

Materials needed:

2x6 & 2x4 Studs
2x4 Treated lumber
4x8 OSB
½"x3¼" OSB strips
1" Foamboard
Tapered shims
16d Nails
8d Nails
2⅜" Collated nails
3¼" Collated nails
1" & 2" Button nails
2½" Concrete nails
¼"x1¾" Concrete screws
4" & 6" Timber screws
Air sealing tape

Tools and equipment needed:

Generator
Extension cord
Circular saw
Chop saw
Reciprocating saw
Framing nailer
Drill and bits
Driver
6' level
4' level
Framing Square
Chalk line
String line
Stepladder

Personal Protection Equipment:

Safety glasses (required)
Work gloves (recommended)
Hearing protection (recommended)

Reference Materials:

Door Schedule

Safety First! Review the Safety Checklist before performing tasks in this chapter.

6.1. FRAMING PORCH

1. Before proceeding check that any OSB in the porch area is covered with ½” foamboard, or that there is 1” foamboard nailed to the wall.
2. At both ends of the porch, place a straight 2x4 held against the outside edge of the concrete against the house. Using a 6’ level, plumb the 2x4 and mark the location of the concrete edges at the top of the wall. Save this 2x4 for use in Step 4 below.
3. Refer to Figure 6-1 for the following steps. At each end of the porch, nail a horizontal 4’ long 2x6 porch frame hanger support flush with the top plate using 16d (or 3¼” collated) nails, holding one end to the line made in Step 1. Once nailed, install three or four 4” timber screws spaced ~12” apart through the 2x6 into the house framing. Tighten the timber screws such that the face of the 2x6 remains vertical.
4. On the outside edge of both 2x6’s, measure in 3” and make a mark. Using a speed square extend the line from top to bottom of the 2x6. These marks represent the outer faces of the porch side framing. On those marks, install a double 2x6 joist hanger with the inside vertical edge of the hanger flush with the line, and the bottom of the hanger 5½” below the top plate. Use two short lengths (3-4” long) of 2x6 blocks set in a joist hanger to serve as a spacer to locate the inside edge of the hanger and to obtain the correct elevation and spacing between the sides of the hanger. Make sure the tops of the blocks are flush with the top plate before nailing the hanger.
5. Using the same 6’ level and straight 2x4 from Step 1, at both ends of the porch slab, plumb down from the face of the 2x6s installed in Step 3, and mark that location on the slab. Measure from that mark to the front edge of the concrete slab at both ends. (If the measurements are different, split the difference). Deduct 4½” (3” from porch edge plus 1½” front porch frame 2x6 thickness = 4½”) from that measurement; this represents the length the of the two outer 2x6 side frame members.

EXAMPLE: Assume the slab depth measures 59”. After deducting 4½” from the depth, the working measurement will be 54½”.

6. Using the working measurement, cut two 2x6’s to that length. Cut two other 2x6s 1½” shorter than that length.

EXAMPLE: For a working dimension width of 54½”, cut two 2x6s at 54½” and two at 53”.

7. For each end of the porch, assemble the side porch frame pieces. Flush one end and the edges of one of the longer 2x6s with one of the shorter 2x6s. At the other end of the assembly, use a 2x4 or 2x6 block to ensure a 1½” offset. Nail the two pieces together with 3¼” collated nails every 12” at an angle so points do not protrude. Take each 2x6 pair and place the flush end into the joist hanger. Make sure the shorter 2x6 faces the center of the porch. Stand a 2x4 (temporary post) on end on the concrete 6” from the unsupported end. Level the 2x6s and clamp and nail the 2x4 to it with two 16d duplex nails. Holding the flush end tight to the house, drive a 6” timber screw through the 2x6

joist hanger support into the ends of each of the side porch frame 2x6s (see detail in Figure 6-1). Then, toenail into it through the 2x6 joist hanger support with 16d nails.

8. At the house wall, measure the distance between the two outside faces of the end pieces. Cut one 2x6 to this length, and one 3" shorter. Lift the shorter of the two into place and nail it to the ends of the inside 2x6 end pieces, keeping the ends flush top and bottom, and the outside end pieces tight. Nail the longer of the two pieces to the ends of the outside end pieces, keeping the ends flush with the outside face of the end piece (see Figure 6-1). Use three 3¼" collated nails at each joint. Nail the 2x6 pairs together with three 3¼" collated nails every 24" along the length of the headers. Use a clamp or other method to keep the top and bottom edges flush. Put the nail in at an angle to be sure the points do not protrude.
9. Cut four 2x6 pieces about 40" long to be used as diagonal braces, after checking the length required. Cut a 45° bevel on each end. These will be installed diagonally in all four inside corners of the porch framing to hold them square (see Figure 6-1).
10. Square the 2x6 pair to the house using the 3–4–5 system or a framing square. At each end of the porch, nail one of the beveled 2x6 braces to the house and the 2x6 pair. Add the two remaining 2x6 diagonal braces. Before nailing the last two braces, sight along the front of the 2x6 pairs to make sure their face is not bowed in or out across the front of the porch. Brace as needed to straighten.

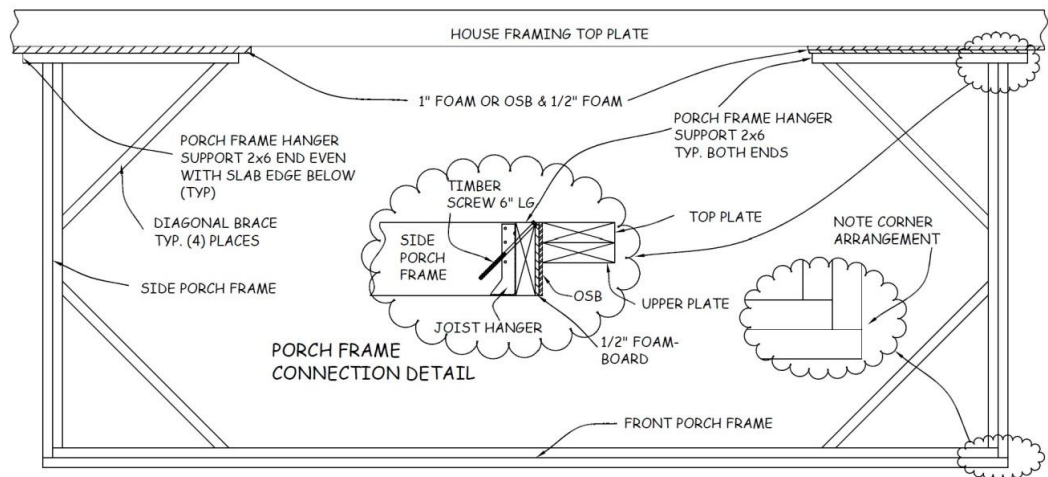

Figure 6-1. Porch Framing.

11. To locate support posts, transfer the corner of the framing above to the concrete below. Place a straight 2x4 held at each outside face at one end of the porch framing. Using a 6' level, plumb the 2x4 at each face, close to the end, and make a mark on the concrete. Repeat at the opposite end of the porch.
12. Using the same method as in Step 11, mark for a center post that in combination with one of the outside posts will "frame" the door. String a tight string line from end to end

at the marks from Step 11 and mark the outside face of the middle post. This will ensure that the bottoms of the three posts are aligned.

13. Set the post anchor plates to the marks made in Steps 11 and 12. Secure with $\frac{1}{4}$ "x $1\frac{3}{4}$ " concrete screws:
 - a. Locate the concrete screws, the $\frac{3}{16}$ " masonry drill bit, and screw drivers in the Anchor Kit.
 - b. Using a $\frac{3}{16}$ " or $\frac{1}{4}$ " drill bit, enlarge the four holes in the mounting plate.
 - c. Using a hammer drill and the $\frac{3}{16}$ " masonry bit, drill one hole, approximately 1" deeper than the length of the concrete screws. (Remove the drill bit from the hole periodically to clear concrete dust, and remove all the dust from the vicinity of the hole so it doesn't get knocked back into the hole.)
 - d. Using the hex driver, carefully drive a screw into the hole until seated tight to the anchor plate. Square the anchor plate and use it as a template to drill the other three holes. Finally, drive the other three concrete screws.
14. Assemble posts, each of which consists of two 2x4's (with their crowns opposite to each other) and $\frac{1}{2}$ "x $3\frac{1}{4}$ " OSB, nailed together. Pre-drill a piece of green treated 2x4 measuring $3\frac{1}{2}$ "x $3\frac{1}{2}$ " and screw it to the bottom of the post using two $2\frac{1}{2}$ " gold deck screws (pre-drilling prevents the green treated piece from splitting).

NOTE: Before measuring and cutting the individual posts, step away from the house and sight along the framing to be sure it is parallel with the top plate of the house wall. Adjust as required.

- a. With a solid face parallel to the front edge of the porch, set a post on top of the concrete screws of each plate and lean it against the porch framing. Pound on the top of the post to get an impression of the concrete screw heads in the bottom treated block. Remove the post and drill a $\frac{1}{2}$ " diameter by $\frac{1}{2}$ " deep hole at each screw location.
- b. Set the post in the same orientation, plumb it, and mark the post at the bottom of the framing.
- c. Label each post for position and orientation, and cut to length.
- d. Measure each post and record the length on each post. Cut the vinyl post sleeves $1\frac{1}{4}$ " shorter than that measurement. Attach the post H-bracket to the top of the posts with $1\frac{1}{2}$ " siding nails (see Figure 6-2). These brackets will be used to secure the top of the post to the porch framing). Slide the post sleeves over each post. One at a time, set one post end on the post anchor plate and raise the other end under the porch framing. Make sure to place the posts with the wide face of the 2x4 facing the street. Plumb it and nail the top of the post in place.



Figure 6-2. Porch Post H-Bracket.

15. Slide the post sleeves up and nail the post anchor plates to the posts with 2½” roofing nails. Slide the post sleeves down over the post anchor plates.
16. To allow for trim ring fit and finish, nail 2x6s to the face of the porch framing, keeping the top edges flush. Use pairs of 16d or 3¼” collated nails spaced about 18” apart.
17. If blocking is required on the side framing to make it flush to the house wall, add an equal amount to the front, so that the porch soffit is the same width both front and side.
18. Install blocking for porch post trim rings as shown in Figure 6-3.



Figure 6-3. Porch Post Trim Ring Blocking.

6.2. FRAMING BASEMENT WALLS

6.2.1. Preparation

1. Before framing any basement wall, check to make sure that all cracks and separations in the floor slab are sealed.
2. Basement walls and components in Bi-level homes may need studs longer than 92 $\frac{3}{4}$ ". Check the House Plan, or with the Construction Supervisor, prior to assembling any basement walls in a Bi-level home.
3. Before building any walls, cut 1" foamboard to cover the foundation walls behind any 2x4 walls. Apply foamboard from the floor all the way up the wall and also on the top of the foundation wall where the sill plate does not cover (see Figure 6-4).

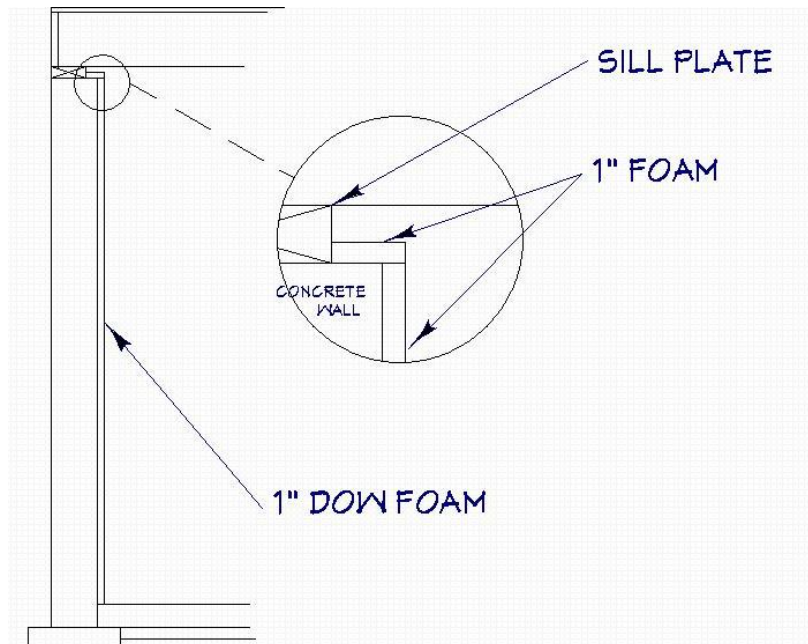

Figure 6-4. Basement Wall Insulation.

4. When applying foamboard around the egress windows, install it with 1" of vinyl and concrete exposed around the window frame perimeter.

6.2.2. Laying Out Basement Walls

1. Referring to the House Plan, lay out the location of all basement walls, snapping chalk lines on each side of the walls. The location of walls labeled "Ref" may not exactly match the House Plan owing to foundation differences. All interior walls that intersect an exterior wall are measured from the inside of the exterior wall.

2. Start by laying out the exterior walls. Where exterior walls meet, abut the corners of the end studs, and nail or screw blocking to the end stud of one wall (see Figure 6-5). Plumb both walls, and nail the non-blocked stud into the blocking to secure the wall.

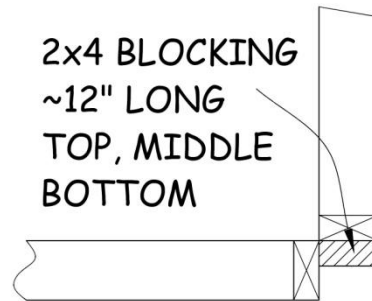

Figure 6-5. Basement Exterior Wall Corner.

3. When laying out the bathroom interior wall, note the location of any concrete floor piping penetrations for toilet and shower drains. Adjust the wall locations as required to maintain the correct spacing from the wall to the pipe centerline as indicated in the House Plan.
4. At corners and intersections, pay attention to which wall end should abut the side of the other wall. Lay out accordingly.
5. Spray all chalk lines with sealer to protect them from the elements.

6.2.3. Cutting Basement Wall Plates

1. All basement wall bottom plates must be treated lumber. Cut upper and treated bottom plates to match the layout on the floor.
2. Check corners to determine which wall end should abut the side of the other wall. This may be dictated by an adjoining door.

6.2.4. Marking Door Locations on Basement Wall Plates

1. Referring to the House Plan and the Table of Door Measurements (Table 6-1), begin by locating and marking the door centerlines using a short VERTICAL line. Overlay that mark with a “C” and an “L” to create a mark for center line: C .

NOTE: The separation between Jack studs (the “rough opening”) for all swinging interior doors is 2” wider than the door size. For all sliding doors, the rough opening is $\frac{1}{2}$ ” wider than the door size (see dimensions in Table 6-1).

2. Mark the location of each door and label with the door size and type (e.g., 4068 Slider).
 - a. For bedroom and bathroom doors, locate the centers such that the hinge-side King/Jack stud pair is at the INTERSECTION of the adjoining wall. This places the hinge side “tight” to the corner for proper door swing but still allows room for trim behind the door.
 - b. For SWINGING closet doors and non-flush sliding doors, locate the centerlines per the House Plan. Measure, locate, and mark the King and Jack studs per Table 6-1.
 - c. For FLUSH sliding doors, locate the inside of the single King/Jack stud pair the specified rough opening distance from the exterior wall (see Table 6-1), e.g., 60½” from the wall for a 5068 door.

NOTE: Ignore what appears to be a small wall section on the House Plan next to the exterior wall. This is an artifact of the CAD software and does not represent an actual wall section. The end of the header will actually be supported inside the exterior wall.

Table 6-1. Example Basement Door Measurements.

Interior Door Type	Rough Opening Width	Header Length	Jack Stud Length
32” Basement Swinging Door	34”	37”	82”
60” Basement Sliding Door	60½”	63½”	83”
60” Basement Folding Door	61½”	64½”	81”

6.2.5. Marking Studs on Basement Wall Plates

1. Lay out studs on 24” centers on upper and bottom plates.
2. If the wall intersects an exterior wall, start from exterior wall end (sheetrocking of interior walls will also proceed from exterior walls inward). If the wall intersects another interior wall, start layout to match likely sheetrock installation.
3. Make certain that door rough openings are at least 3” from the end of the wall panel to permit later installation of door trim. The King and Jack studs provide sufficient space for the 3” door trim.
4. Where a door will be attached at the end of a bathroom or bedroom wall, mark the end of the wall for a 2x4 L-corner oriented to allow nailing through the L-corner into the King stud of the door as shown in Figure 6-6 (similar to the 2x6 L-corners used in the exterior walls). If doors are to be attached on both sides of this same wall, omit the L-stud, and orient the additional 2x4 as shown.

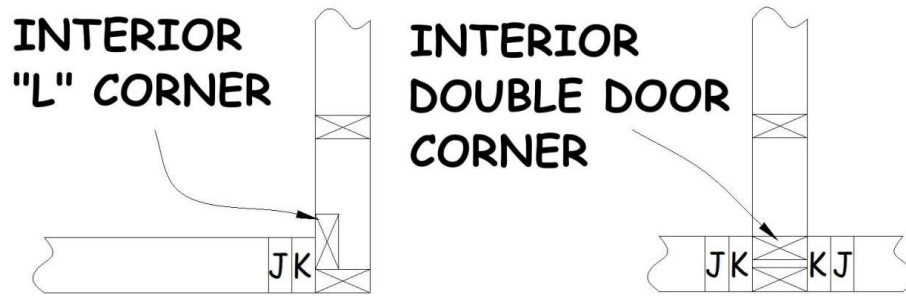

Figure 6-6. Corner Construction.

5. When complete, label upper and bottom plates and tack together with duplex nails. Mark compass orientation and label both plates and floor with an identifying number.
6. Hold the framing around the egress windows back $\frac{1}{4}$ " from the outside edge of the window frames. If this is not done, sometimes finished drywall sticks past the inside frame of the window after the sheetrocking and plastering are completed.

6.2.6. Building Basement Walls

1. Basement walls are constructed in the same manner as other interior walls (see Section 5.8), but use treated bottom plates.
2. Make the height of basement walls $\frac{1}{4}$ " shorter than required so they can be set in place without force. Place upper and bottom plates on the floor in position between the snapped chalk lines. At several locations, measure the distance from the top of the two plates to the bottom of the I-joists or beam above. Subtract $\frac{1}{4}$ " from the shortest of the measurements and cut the studs to that length.

NOTE: Here's an alternative method which eliminates measuring!
Number the studs and plate locations to ensure proper placement when assembling the wall. At each stud location, stand on the top/bottom plate pair (to eliminate any gaps) and place one end of a stud on the plates. Hold it close to plumb against the floor joist or beam, and make a mark on the stud at the bottom of the joist or beam. Draw a square line at the mark, and cut the stud to length on the non-waste side of the square line ("take the line").

3. If there are any doors in the wall, cut the top end of the pre-assembled component King/Jack pairs to the correct length prior to assembling the King/Jack pairs to the header. Then install the assembly in the wall. If there is a door in the wall under the beam, omit the header and use King/Jack pairs that are the same length as the other studs in that wall (both King and Jack are the same length).
4. If the wall contains one or more windows, omit the King and any Short studs and install them after the wall is plumbed and anchored.

5. Assemble the walls in the usual fashion. Attach the upper and bottom plate to each stud using two 16d or 3¼” collated nails through the plate into each end of the stud.
6. Where a flush sliding door intersects another wall, install a 2x4 block with the top edge 84½” from the floor to support the door header.
7. Tip the walls upright and align the bottom plate with the floor chalk lines. Use tapered shims to take up any space above the upper plate, and plumb the wall. Nail the bottom plate to the floor using 2½” concrete nails, one between each stud. Double check alignment with the chalk lines as each concrete nail is installed.
8. Recheck the wall for plumb, and nail the upper plate to each I-joist using two 3¼” collated nails.

NOTE: Before anchoring either the top or bottom of the exterior walls, check for plumb at the corners and at several locations along the length. The masonry walls may not be plumb and it may be necessary to move the 2x4 wall away from the concrete at either the top or bottom.

9. Foamboard insulation must held tight to the foundation wall following erection of the stud wall. Nail scrap OSB or 2x lumber, using 2¾” collated or 8d nails, to the wide side of studs as required to hold the foamboard against the foundation wall. Scrap 1” foamboard may also be used for this. Nail the foamboard to the studs using 1½” siding nails or 2” button nails.
10. Window framing consists of a T-header, a sill, and two King studs (no Jack studs). Install the King studs by toe nailing with 16d nails (or 3¼” collated nails) to the top and bottom plates after carefully aligning the inside faces of the King studs 1” outside of the inside vinyl window frame. Consistent reveal of the vinyl frame is important for a good look when finished.
11. Measure the distance between the King studs at the top and or bottom (they should be the same) and cut the T-header and sill 2x4 to that length. Leaving 1” of reveal of the vinyl frame below the bottom face of the header, and above the top face of the sill, nail through the King studs into the ends of the header and sill. Be sure both header and sill are level.
12. Add Short studs as required below the sill to match the 24” stud spacing. Short studs are not required above the T-header.
13. Walls parallel to the I-joists require blocking at the top. Nail 2x4s between the bottom I-joist flanges at 24” O.C., flush with the bottom of the I-joist flange (see Figure 6-7).

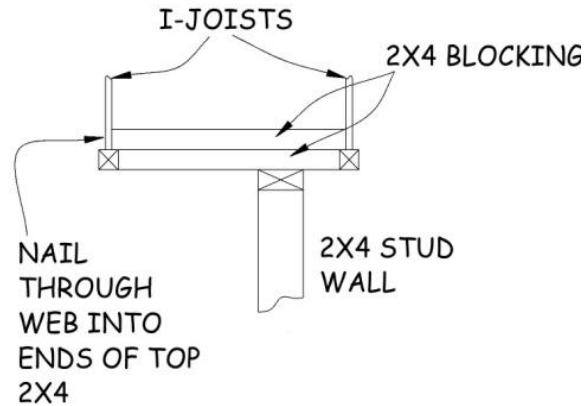

Figure 6-7. Blocking for Attaching Basement Walls Between I-joists.

6.3. CUTTING ANGLE STAIRWAY WALL

1. Both stairway walls are built and installed full height. One of these walls must be cut at an angle to allow large items (e.g., mattresses) to be turned at the bottom of the stairs. The top of the angle wall should be 42" above the nose of the stair treads.
2. Typically, the studs are not aligned with the nose of the treads so an added step is required. At the bottom of the stairs, lay a 6' straight-edge on the steps. Hook a tape under the straight-edge at the bottom stud and the upper stud, measure up 39", and make a mark on each stud. Place the straight edge on these marks and scribe an angled line on all the covered studs. Remove the entire middle stud.
3. Using a speed square, scribe marks around the other three sides of the studs that are to be cut to aid in cutting at the proper angle. On the top stud that is not to be cut, mark the lower face to locate where the bottom edge of the upper plate will be attached.
4. Measure and cut the 2x4 upper plate, cutting the ends at the same angle marked on the studs.
5. Set a circular saw at the angle on the side of the studs (about 38°) and cut each stud at the lines scribed in Step 2 above.
6. Tack the upper plate to the top, uncut stud, and through the upper plate into the top ends of the cut studs. Check that the upper plate is parallel with the angle of the stairs and is 42" above the nose of the treads. Nail with two 16d (or 3/4" collated) nails through the upper plate into the ends of the cut studs, and through the top plate into the uncut stud at the top.
7. To stiffen the wall, cut and nail an angled 2x4 brace between the bottom of the uncut stud and the top of the next cut stud, through the space where the stud was removed earlier (see "A" in Figure 6-8).

- Align a straightedge with the upper and bottom plate locations of the stud removed earlier, and mark that location on the angled brace.

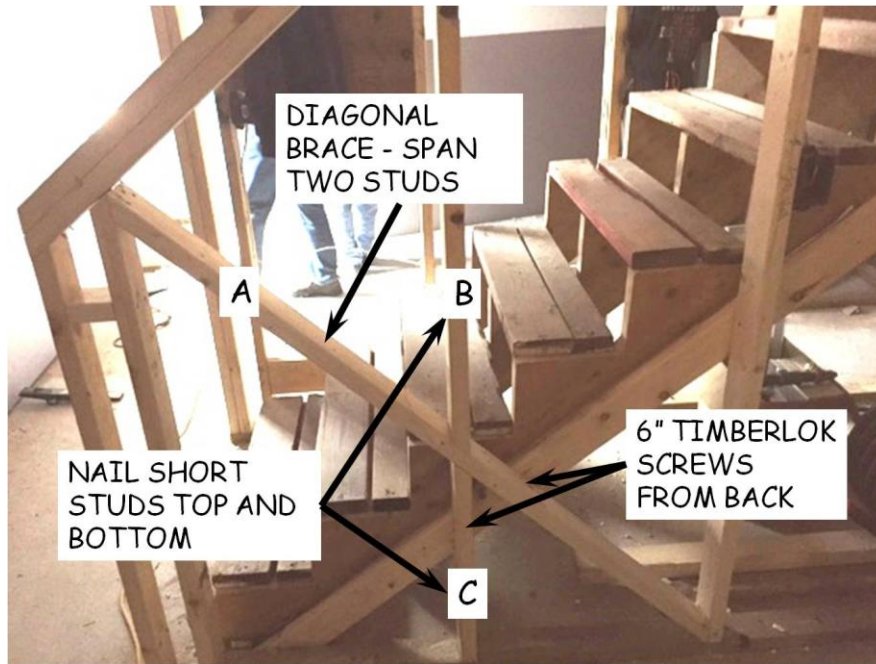

Figure 6-8. Stairway Wall Bracing.

- Cut the original upper plate where it intersects the uncut upper stud and remove it from the underside of the floor framing.
- Measure and cut, at the same angle, two 2x4s to fit above and below the angled brace as shown in Figure 6-8, “B” and “C”, respectively. Toenail the lower (“C”) to the bottom plate and through the diagonal brace into the top. Nail the upper (“B”) through the upper plate into the top end and then through the diagonal brace into the lower end. Use two 3/4” collated nails at each location.
- Nail the top plate on top of the upper plate using pairs of 16d (or 3/4” collated) nails at each stud.
- Finally, drive a timber screw through the stringer/OSB/2x4 sandwich into the diagonal brace, and another into the lower Short Stud (“C”) as indicated in Figure 6-8.

6.4. FRAMING STAIRWAY CLOSET PLATFORM

- If the House Plan calls for a kitchen cabinet rather than a closet, go to Section 6.5.

2. A bedroom closet extends over the stairway in most homes. It may extend as far as 24" over the opening. The top of the platform will be 20" above the $\frac{3}{4}$ " OSB decking on the main floor.

REQUIREMENT: If the closet extends too far out or is too low, it will not meet code for headroom requirements, which is a minimum of 76" vertically to the stair tread below.

3. Build a $15\frac{3}{4}$ " tall 2x4 wall 40" long, using $12\frac{3}{4}$ " long studs (**24" o.c.**) with upper and bottom plates. Nail it to the floor with the bottom plate flush with the stairway opening that's above the lower end of the stairs. Plumb the wall and nail the ends to the adjacent studs. When the 2x4 platform is constructed in the next step, it is set on top of this wall, for a total height to the top of the closet deck of 20" above the floor decking.
4. Build a 27"x40" platform with 2x4 joists (16" o.c.) and $\frac{3}{4}$ " OSB decking as shown in Figure 6-9. The stairway opening is typically 40" wide. Adjust the platform width as necessary to fit between the walls. The 2x4 that bridges the stairway opening on the cantilevered end should be 46" long so that it can be firmly supported with blocking or a stud inside the adjoining walls. Check the location of the wall studs to be sure that the 2x4 will not interfere on either side (see Figure 6-10). Once the platform is in place, with one end sitting on the short, 2x4 stud wall at the end of the opening, the other end will extend 24" over the opening. Adjust if necessary so long as the platform does not extend more than 24".

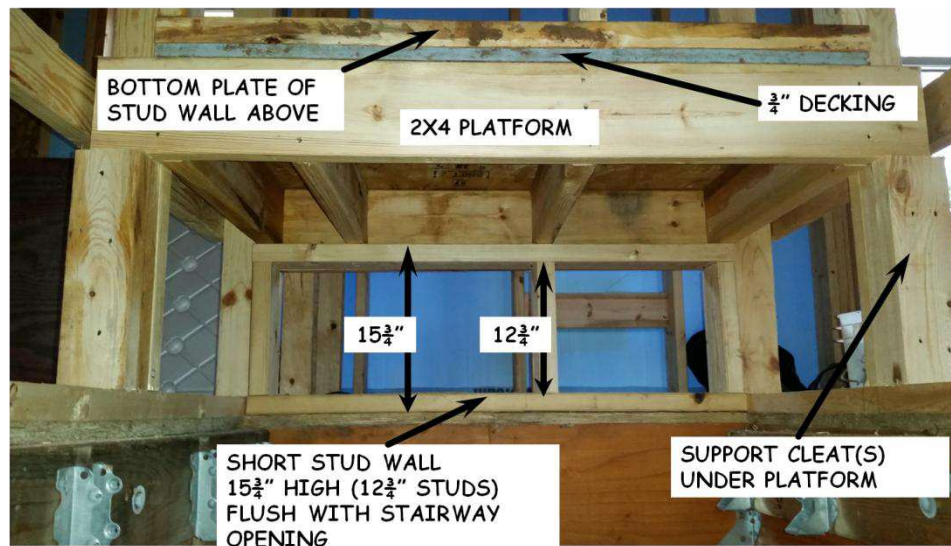

Figure 6-9. Closet Platform.

5. Set one end of the 2x4 platform on top of the short wall and nail in place. Level the platform in both directions and nail the sides of the platform to the wall studs on both sides of the stair opening. Where the 46"-long frame member extends into the side walls, do one of the following to support it:
 - a. Install blocking between the existing wall studs to give adequate support, or

- b. Install an extra stud on either or both sides to which the 2x4 can be nailed.

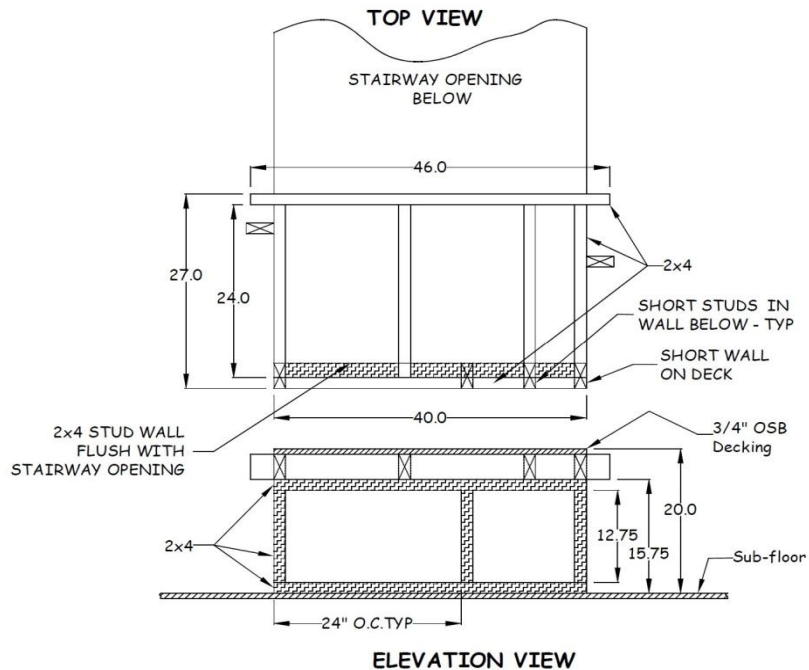

Figure 6-10. Platform for Closet Over Stairway.

6. Cover the entire platform with $\frac{3}{4}$ " OSB decking, nailing it every 9" with 8d nails. The decking can consist of more than one piece as long as the OSB edges are properly supported.
7. At the end of the platform toward the top of the stairs, build a short 2x4 wall high enough to match the height of the adjoining full-height walls. Nail to the platform and to the adjoining walls. Install blocking in the side walls if necessary.

6.5. FRAMING STAIRWAY CABINET OPENING

1. The opening for this cabinet cavity is typically located in the wall above one side of the stairway (the "side wall"), at the end toward the bottom of the stairs. A full height wall (the "end wall") should exist at the end of the opening above the bottom of the stairs, flush with the opening below.
2. Install a stud in the side wall flush to the stairway opening side of the end wall. Install another stud in the side wall 31" inside-to-inside from the first stud, toward the top of the stairs (see Figure 6-11).

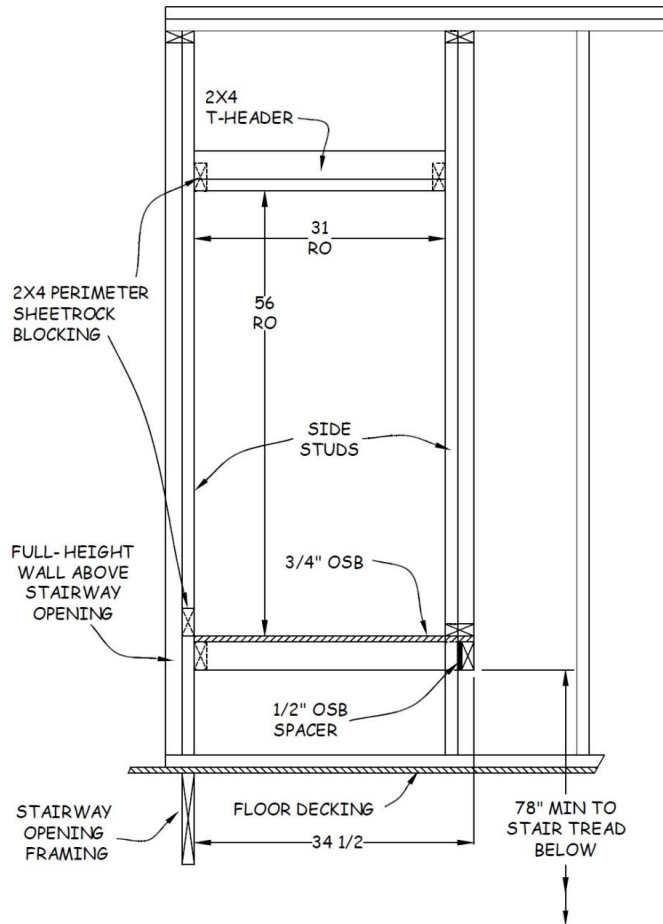

Figure 6-11. Stairway Cabinet Opening Framing.

3. Any existing studs between these two studs must be removed. These newly installed studs (the “side studs”) will define the sides of the cabinet opening.
4. Assemble a platform 40”x34½”, similar to that described in Section 6.4.4.
5. Locate the stair tread that is vertically below the location of the stud that was installed 31” from the end wall. From that tread, measure vertically up 78” and mark the stud. Install the platform with the bottom of the framing at or above that height. Level the platform in all directions, and nail it with 3¼” collated (or 16d) nails through the perimeter 2x4 framing into any adjacent studs.
6. Create a short wall with the top at the level of the platform by cutting a 2x4 31” long to use as a top plate. Nail it between the side studs, flush with the top of the platform OSB decking. Provide short studs below this top plate on the same 24” O.C. spacing as the rest of the wall.
7. Create a 31” long T-header and nail it between the side studs with the bottom 56” above the platform deck.

8. Measure from the top of the platform deck to the top of the side wall top plate, and create a stud wall this height to install on top of the platform deck. Install the wall flush with the edge of the platform deck that is toward the top of the stairs. Check that the inside of the wall is flush with the side stud at the opening.
9. Nail 2x4s to serve as sheetrock blocking around the top perimeter of the cabinet cavity, with the bottoms 56" above the platform deck, the same elevation as the bottom of the T-header.
10. For the same purpose, nail 2x4s between studs in the end wall and the wall at the back of the cavity, with the bottoms even with the top of the platform.
11. Cut a 2x4 28" long and nail between the top perimeter blocking to support the cavity ceiling sheetrock. Locate the 2x4 parallel to the stairway, midway between the front and back of the cavity.