

## Chapter 24. Picnic Table Construction

### 24.1 CUTTING PICNIC TABLE COMPONENTS

### 24.2 ASSEMBLING PICNIC TABLE

### 24.3 FINISHING TOUCH

### 24.4 MATERIALS SHEET

#### Tools needed by volunteers:

Pencil  
Tape Measure

#### Materials needed:

2x6 Treated lumber  
2x4 Treated lumber  
5/16" x 3½" Carriage bolts  
5/16" Washers  
5/16"-18 UNC nuts  
2½" Square drive [exterior](#) screws  
Scrap 2x lumber

#### Tools and equipment needed:

One 100' extension cord  
Two 50' extension cords  
Chop saw  
18-Volt circular saw  
Two 18-volt drills w/1/8" and 11/32"  
drill bits  
Four 18-volt drivers with #2 square  
drive bits  
Eight 18-volt batteries  
Two battery chargers  
Tape measure  
Wrench - ½" or adjustable  
Clamp  
Framing square  
Hammer  
Pencil  
Black Permanent marker

#### Personal Protection Equipment:

Safety glasses (required)

**Safety First! Review the Safety Checklist before performing tasks in this chapter.**

## 24.1. CUTTING PICNIC TABLE COMPONENTS

1. Cut all pieces required per the cut sheet dimensions (see Figure 24-1).

**NOTE:** Lumber does not always come with square ends; cut the ends square, if necessary.

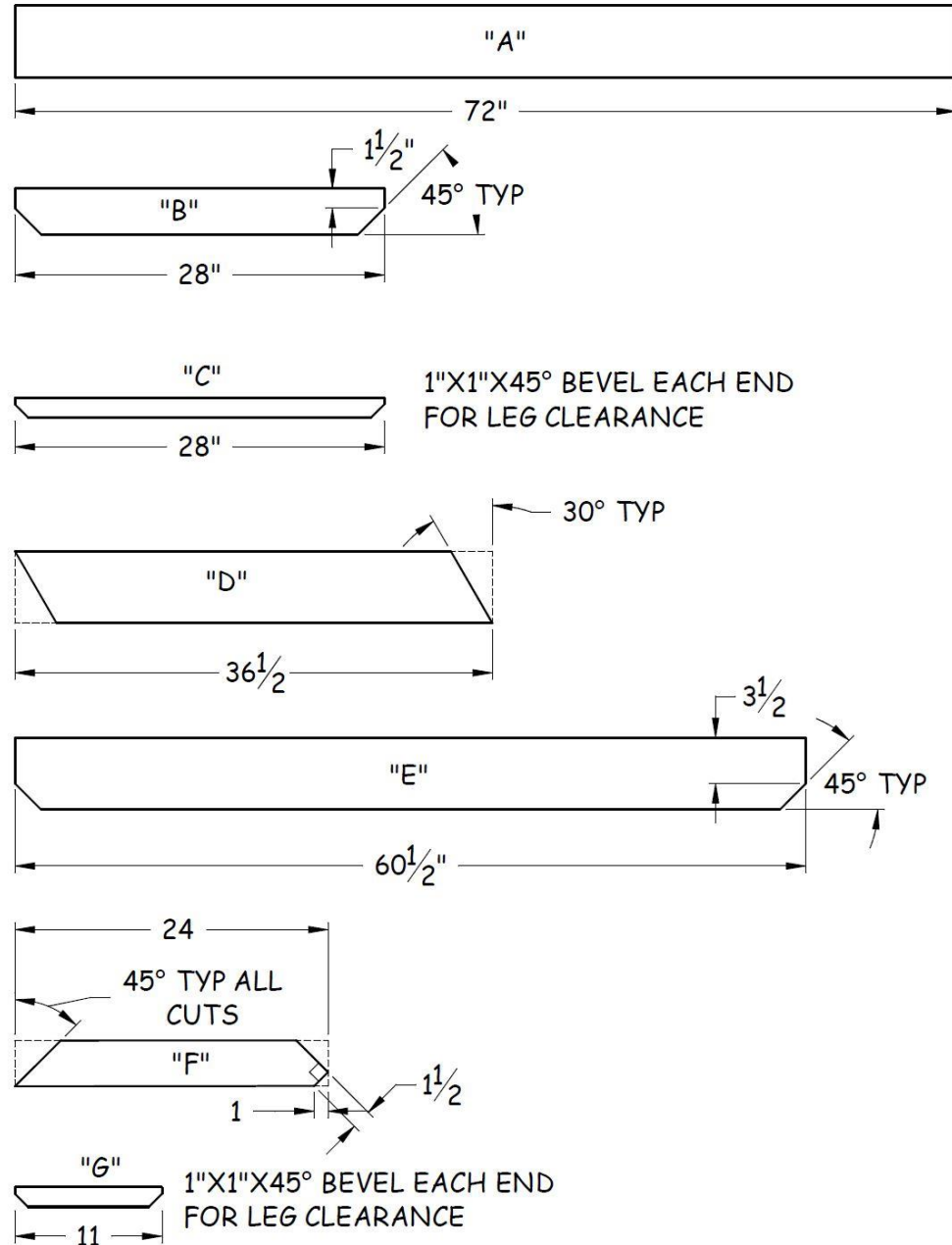

Figure 24-1. Picnic Table Cut Sheet.

2. Table 24-1 lists the number of pieces required for each component.

**Table 24-1. Picnic Table Components.**

<b>Component</b>	<b>Quantity</b>	<b>Description</b>
A	9	2 x 6 x 72"
B	2	2 x 4 x 28"
C	2	2 x 4 x 28"
D	4	2 x 6 x 36½"
E	2	2 x 6 x 60½"
F	2	2 x 4 x 24"
G	2	2 x 4 x 11"

3. Table 24-2 presents a cut list describing how to minimize waste when cutting the components for the table.

**Table 24-2. Picnic Table Cut List.**

<b>Lumber</b>	<b>Component(s)</b>	<b>Number of Pieces</b>
2x6x12	A	2
2x6x12	A	2
2x6x12	A	2
2x6x12	A	2
2x6x12	A	1
2x6x12	D	2
	E	1
2x6x12	D	2
	E	1
2x4x8	B	2
	C	1
	G	1
2x4x8	C	1
	F	2
	G	1

## 24.2. ASSEMBLING PICNIC TABLE

### 24.2.1. Leg Assembly

1. On each Component "B", measure in 6" from each end along the non-beveled edge (top of piece) and draw a horizontal line along the top edge of the component, square to the face.
2. On each Component "E", measure in 15" from each end along the non-beveled edge (top of piece) and draw a horizontal line along the top edge of the component, square to the face.
3. On each Component "D", measure up 19" from the base of the leg and draw a horizontal line along the outside edge of the component, square to the face.

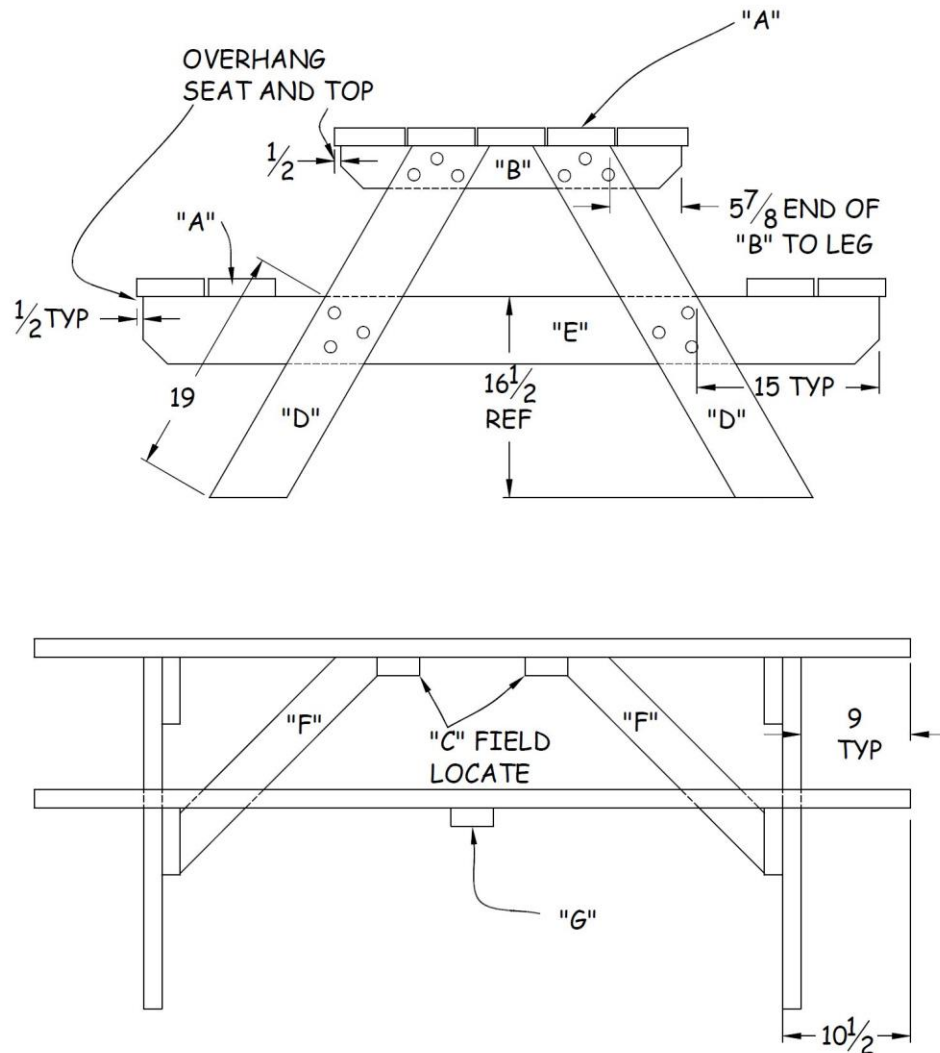

Figure 24-2. Picnic Table Assembly.

4. To build one leg assembly, place one Component “B” and one Component “E” parallel to each other on a flat surface. Lay a pair of legs (Component “D”) on top of the first two components so they approximate the arrangement in Figure 24-2. Place scrap 2x support blocks under the four intersection points.

**NOTE:** The scrap is needed to protect the drill bit from being damaged when drilling through the components.

5. Position the legs so they are inside the 6” marks on Component “B” and the cut angles of the legs are flush with the top of Component “B” (see Figure 24-2). Drill three 11/32” holes through each Component “D” into Component “B” at least 1” from the edges (to avoid component failure). Insert one 3½” carriage bolt into each of the six holes (to anchor the three pieces into position).
6. Position Component “E” under the two legs so that each 15” mark on its top edge aligns with the 19” mark on the corresponding Component “D”. Drill three 11/32” holes through each Component “D” into Component “E” at least 1” from the edges (to avoid component failure). Insert one 3½” carriage bolt into each of the six holes (to anchor the three pieces into position).
7. Raise the assembly into an upright position, tap all twelve bolts completely into the assembly, and secure them with 5/16” washers and nuts.
8. Repeat process for the second leg assembly.

### 24.2.2. Seat Bench Assembly

1. Set both leg assemblies on a flat surface in an upright position (as in final assembly), oriented so the heads of the bolts are on the outside of the assembly.
2. Make marks along the outside edge of a seat (Component “A”), square to the face and located 10½” in from each end of the seat.
3. Place the seat (Component “A”) on top of the two bench supports (Component “E”) so the outside edges of the bench supports are aligned with the marks on the seat and with the long edge of the seat extending ½” beyond the ends of both bench supports.

**NOTE:** It is critical that both leg assemblies remain perpendicular to the ground when the bench pieces are being attached.

4. Drill two ⅛” pilot holes through the seat into each bench support, about 1” in from each edge of the seat. Attach the seat to the bench supports using 2½” exterior screws at each anchor point (see Figure 24-2).
5. Repeat Steps 2 through 4 for the seat bench on the other side of the table.

6. Position a second seat (Component “A”) on the bench support spaced  $\frac{1}{8}$ ” from the first seat and with ends aligned with those of the previously installed seat. Attach it to the bench supports using  $2\frac{1}{2}$ ” **exterior** screws at each anchor point, as in Step 4 above.

**NOTE:** The  $\frac{1}{8}$ ” spacing is typically maintained by inserting several 8d nails between the two seats.

7. Repeat Step 6 for the second seat on the opposite seat bench.

### 24.2.3. Build Tabletop

1. Position the tabletop pieces (Component “A”) centered on top the bench leg assemblies so that each end of a tabletop piece is 9” from the outside face of its associated Component “D”. Position the outside two tabletop pieces so they each extend  $\frac{1}{2}$ ” beyond the ends of both Component B pieces. Space the interior three tabletop pieces so the gaps between the boards are equal and the table top is evenly distributed across the top of the Component “B” pieces (see Figure 24-2).
2. Starting with an outside tabletop piece, drill two  $\frac{1}{8}$ ” pilot holes through the piece into one Component “B”, about 1” in from each edge of the tabletop piece. Attach the tabletop piece to Component “B” using  $2\frac{1}{2}$ ” **exterior** screws at each anchor point.
3. At the opposite leg assembly, position a framing square vertically under the tabletop piece just attached in Step 2 above, placing the long leg of the square against Component E and the short leg under the table top. Square the assembly and attach the tabletop piece to Component “B” corresponding to this leg assembly as in Step 2 above.
4. Attach the remaining tabletop pieces to the Component “B” pieces using  $2\frac{1}{2}$ ” **exterior** screws at each anchor point as in Step 2 above.

### 24.2.4. Add Supports

1. Position scrap 2x material on the ground to prevent damage to the table top and carefully flip the table over so it is resting on its top.
2. Attach bench supports (Component “G”) centered between the leg assemblies of each bench. Use two  $2\frac{1}{2}$ ” screws in each bench board.
3. Attach an angle support (Component “F”) to the center of Component “E” on one leg assembly using two  $2\frac{1}{2}$ ” **exterior** screws. Make sure the double-notched end is positioned up, flush to the underside of the table top, and located in the center of the table. See Figure 24-2 for proper location of pieces.
4. While maintaining the legs square to the table top, make a mark on the underside of the table top at the notched end of Component “F”. Using a framing square,

transfer that mark to the bottom of each of the two outermost planks on the table top.

5. Attach tabletop support (Component “C”) flush to the notched end of Component “F” and the three marks made in Step 4. Use two 2½” exterior screws in each top piece (Component “A”).
6. Secure Component “F” to Component “C” by driving a 2½” exterior screw through Component “C” into Component “F”.
7. Repeat Steps 3-6 for the opposite angle support.
8. Turn the table over and secure each Component “F” to the table top by driving a 2½” exterior screw vertically through the table top piece (Component “A”) into Component “F”.

### **24.3. FINISHING TOUCH**

1. Using the permanent marker, have all participants sign the tabletop. Scripture, poems, messages, and drawings are welcome additions.

### **24.4. MATERIALS SHEET**

1. For each picnic table, the build site must be supplied with the materials specified in Table 24-3.

**Table 24-3. Picnic Table Materials Sheet.**

Quantity	Description
8	2x6x12' treated lumber
2	2x4x8' treated lumber

**NOTE:** This provides one 2x6 drop of 6' and one extra 2x6x12' piece that can be used for contingency or on another picnic table.