

## Chapter 5. Build Main Floor Walls

- 5.1 FRAMING EXTERIOR WALLS
- 5.2 SQUARING EXTERIOR LONG WALLS
- 5.3 SHEATHING EXTERIOR LONG WALLS
- 5.4 ERECTING EXTERIOR LONG WALLS
- 5.5 SHEATHING & ERECTING SHORT WALLS
- 5.6 COMPLETING EXTERIOR WALLS
- 5.7 STRAIGHTENING EXTERIOR HOUSE AND ATTACHED GARAGE WALLS
- 5.8 FRAMING INTERIOR WALLS
- 5.9 ERECTING FULL-HEIGHT INTERIOR WALLS
- 5.10 ERECTING HALF-HEIGHT INTERIOR WALLS
- 5.11 INSTALLING TOP PLATES

### Tools needed by volunteers:

Hammer  
Nail apron  
Tape measure  
Square  
Utility knife  
Pencil

### Tools and equipment needed:

Generator  
Extension cord  
Circular saw  
Chop saw  
Reciprocating saw  
Framing nailer  
50' Steel tape  
6' level  
4' level  
Framing square  
Chalk line  
Pry bar  
String line  
Sledgehammer  
Stepladder

### Materials needed:

Pre-marked wall plates  
Door and window components  
2x6 and 2x4 Studs  
16d Nails  
16d Duplex nails  
8d Nails  
3/4" Collated nails  
2 3/8" Collated nails  
1" and 2" Button nails  
2" Drywall screws  
2 1/2" Deck screws (tan-colored)  
4" and 6" Timber screws  
4x8 OSB  
1" Foamboard  
1/2" Foamboard  
House wrap  
Air sealing tape  
Flashing tape  
Construction adhesive  
Air sealing caulk  
Spray foam

### Personal Protection Equipment:

Safety glasses (required)  
Work gloves (recommended)

**Safety First! Review the Safety Checklist before performing tasks in this chapter.**

## 5.1. FRAMING EXTERIOR WALLS

1. Assemble each exterior wall on the deck and then erect it in one complete section. Assemble the two long walls first. Assemble and erect the short walls after the two long walls are up.
2. Before separating the upper and bottom plates of the long walls, check for marks on the inside edge of the bottom plate 5½” from each end of the plate. Before assembling the wall, align these marks close to the chalk lines of the adjoining short walls. Once the wall has been lifted, this will help properly position the wall end-to-end.
3. Remove the temporary nails connecting upper and bottom plates of the wall section and separate on the deck. Be sure the words “Upper” and “Bottom” remain in the same orientation.
4. If not presorted, select studs for framing walls by sighting along the edge of each stud to determine whether the stud is crowned. If crowned, mark with an arrow pointing to the high side; if not crowned, mark with an arrow pointing to one end of the stud. Do not use studs if they are severely crowned (ask yourself, “Would I use this for my house?”). Place studs with “crown up” and window and door components in position between plates per markings on upper and bottom plates. Make certain that the flush side of the window and door headers faces up. Check the jack studs in the door components for any twist. Replace if they are twisted as this will cause problems during door installation.

**NOTE:** Set aside the straightest studs for use in the kitchen walls and bathroom tub wall.

5. Preassemble 2x6 corners ensuring that end and side surfaces are flush, nailing every 10” - 12” along the length with ¾” collated nails or 16d nails. Place the “L” “down” at end of the wall, flush with ends and sides of the upper and bottom plates; nail with three ¾” collated nails or 16d nails into each piece.
6. Make sure the edges of the studs are flush with the edges of the plates and that the end studs or corner assemblies are flush with the ends of the plates. Using a plastic speed square with a corner cut off, make a mark on the inside face of each plate at each layout mark to ensure the stud is square to the plate prior to nailing. Align the stud to this mark on the inside of the plate and nail one ¾” collated nail or 16d nail through the plate into the bottom third of the stud. Then square the stud to the line and nail two more ¾” collated nails or 16d nails into the stud through the plate, one in the middle and one near the top, taking care to keep hands and body parts away from the nailer. Use a tool to twist the stud to square, if required.
7. Field cut short studs for each window, measuring for length next to the nearest stud. Transfer locations for these short studs from the bottom plate to the window sills and nail in place with three ¾” collated nails or 16d nails at each end.
8. The non-zero end of a wall may have an extra stud near the second-last 24” o.c. stud. If the two studs are in direct contact, screw them together with three ½” deck screws. If

the two studs are separated, fill the gap with multiples of ½” foamboard and then screw the studs together with three 4” timber screws to create a tight stud/foamboard “sandwich.”

## 5.2. SQUARING EXTERIOR LONG WALLS

1. After each long wall is assembled on the deck, align the bottom of the wall’s bottom plate so it is flush with the chalk line along the entire length of the wall. Use a hammer to toenail through the bottom face of the bottom plate into the deck with 8d nails approximately every 8’.
2. With a long steel tape, “burn a foot” and use diagonal measurements to square up the wall, moving the top of the wall UNTIL BOTH MEASUREMENTS ARE EXACTLY THE SAME (a difference of no more than 1/16”). **(Use good “corners” and the same edge of the tape at each end when making these measurements.)** Using a hammer, tack the upper plate to the deck with three or four 16d duplex nails through the top face so it will not go out of square.

## 5.3. SHEATHING EXTERIOR LONG WALLS

1. Cut four 5¼” x 92½” pieces of 1” foamboard (or two pieces of 2” foamboard) and insert into the L-corner. Tape or tack in place. Do this before attaching any OSB to the corner. Cut additional 5¼”-wide pieces of foamboard to create stud-foamboard-stud “sandwiches” where studs are less than 3” apart. Use 4” timber screws if the “sandwich” is 1½” wide or less. Use 6” timber screws if the “sandwich” is wider than 1½” but less than 3”. Drive both 4” and 6” screws at an angle so they don’t go all the way through the “sandwich”.
2. Check the House Plan to see where sheets of 4’x8’x½” OSB wind bracing are to be located on each wall section and secure them to the studs. Each OSB sheet at the ends of the wall should be centered on the stud nominally 48” from the end of the wall and flush with the bottom plate but not necessarily flush with the end studs. The “reveal” at the wall end should be consistent from top to bottom—a sign that the wall is square. Tack in place using one 8d nail in each corner. Check that the wall remains square before nailing permanently. If the House Plan calls for wind-bracing in the center of the wall, place a 4x8 sheet of OSB centered on studs and flush with the bottom plate. Mark all wind bracing sheets with a large “WB” using red crayon.
3. If one of the long walls is the front wall of the house, the rest of this wall may require sheathing with OSB. Consult the Construction Supervisor to determine if this is the case. If yes, sheathe the entire wall with OSB, cutting pieces to fit below windows. It is not necessary to put OSB above doors or windows.
4. Using a T-square, or measurements, draw a line on all OSB sheets at all studs within the sheets to help ensure that the nails do not miss. Fasten all **wind bracing** OSB sheets with 2⅜” collated nails or 8d nails into each stud and the upper and bottom plate with a maximum 6” spacing. Fasten all **non-wind bracing** OSB sheets with 2⅜” collated nails

or 8d nails following the Non-Wind Bracing Nailing Pattern: seven equally spaced nails down each side stud, five down the middle stud, and two between each stud in the upper and bottom plates (see Figure 5-1). After all the OSB sheets are fully nailed, pull the nails that are securing the upper plate of the wall to the deck.

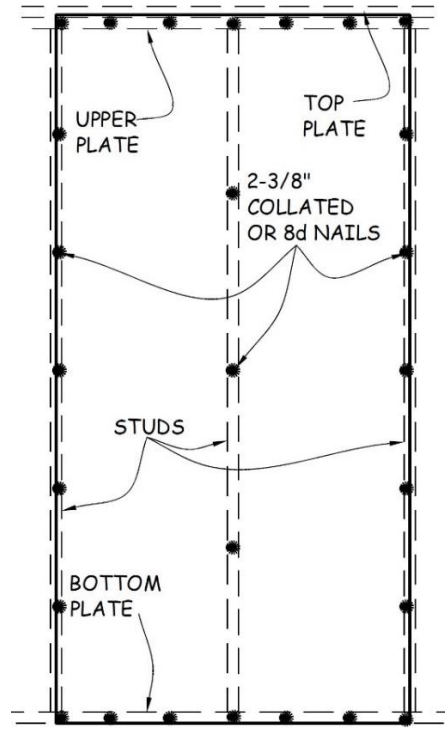

**Figure 5-1. Non-Wind Bracing OSB Nailing Pattern.**

5. Measure the width of the house wrap and subtract  $14\frac{3}{4}$ " from that width (e.g., if the wrap is 18" wide:  $18" - 14\frac{3}{4}" = 3\frac{1}{4}"$ ). Measure up from the bottom of the wall that amount and snap a chalk line the length of the wall above the bottom plate. Position the wrap so it extends about 12" beyond both ends of the wall and staple the top of the wrap to the chalk line at each stud and over any OSB, leaving a little slack at the edges of any OSB sheets to allow foamboard to be installed tightly to the OSB edges. Foamboard will be installed over the house wrap.

**NOTE:** Once the wall is erected, the wrap will hang the proper amount below the wall to shed water away from the house at any horizontal seam. The bottom of the wrap will fall slightly below the bottom of the foam sheathing and slightly over the 2" foundation foam.

6. On side and back walls, install 1" foamboard sheathing between OSB wind bracing, over the house wrap and flush to the bottom of the bottom plate. Position the foamboard so the grooved side is butted up against any OSB. If this is not possible, cut off the "tongue" of the foamboard before placing it next to the OSB. Nail the foamboard with 2" button nails following the Foamboard Nailing Pattern: seven equally spaced nails down each side stud, five down the middle stud, and two between each stud in the upper and bottom plates (see Figure 5-2). The seven nails down each side stud can be shared

between two abutting pieces of foamboard. Position the nail in the middle of the gap between the two so that the “button” holds both pieces of foamboard in place (see Figure 5-2).

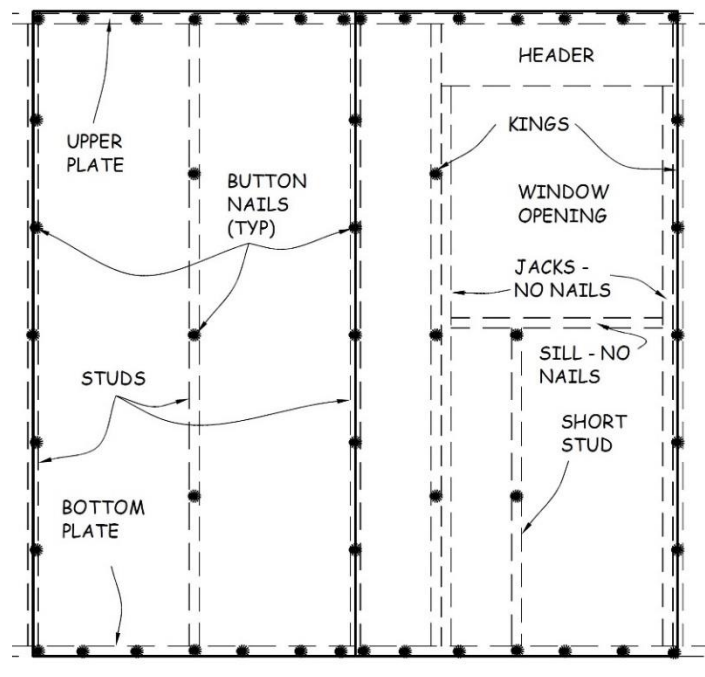

**Figure 5-2. Foamboard Nailing Pattern.**

7. Around windows and doors, nail only into the King studs and into the header, making sure nails are 2/4” away from the opening. Do **NOT** nail into the window sill; **nail only into the short studs (SX) below the window sill**. This will prevent nails from interfering with the window flanges during window installation.

**NOTE:** Avoid using full 4x8 sheets of foamboard over windows and doors. Use scrap pieces that cover at least the King/Jack pairs and are centered on short studs below windows. Fill gaps on headers and below windows with smaller pieces, but do NOT create any horizontal seams.

8. Install 1/2” foamboard over all OSB, flush on all sides. Nail with 1” button nails following the Foamboard Nailing Pattern described in Section 5.3.6 and shown in Figure 5-2. Tape all seams and any broken score lines with air sealing tape.

**CAUTION:** Install 1/2” foamboard over OSB designated as wind bracing **ONLY** if wind bracing inspection IS NOT required or inspection has been completed (see Construction Supervisor).

9. After the wall has been sheathed, lift the bottom edge of the house wrap up, taut onto the sheathing, and tape this edge to the sheathing with air sealing tape every 3’–5’.

**NOTE:** This will keep the house wrap out of the way when erecting the wall in the next section.

## **5.4. ERECTING EXTERIOR LONG WALLS**

1. Apply two generous beads of air sealing caulk parallel to each other along the entire length where the wall will stand, except at door openings. Stay at least 2" away from the chalk line and the deck edge. Apply a bead of caulk, perpendicular to these two beads, at both ends of the floor deck and at each side of any door opening, connecting them in a large rectangle. This will help to ensure a complete air seal.
2. Assemble two temporary braces for each long wall. Attach a 2x4x24" spacer block to the lower inside end of a 14' or 16' 2x4 brace. Align the spacer block with the end of the brace and nail a single 16d duplex nail through the long brace into the center of the spacer block. This spacer block will allow clearance for the 1" foamboard on the short walls when they are erected. With one 16d duplex nail, attach a 2x4 brace to each long wall end stud near the upper plate to serve as a temporary support.
3. Stand the wall section up, and move the inside of the floor plate flush to the chalk line on the deck along its entire length. Be sure to align the 5½" marks on the bottom plates (made in Section 3.2.5) with the adjoining chalk lines (as a result, the ends of the wall may not necessarily align with the edge of the deck). Nail the wall to the deck with two 3¼" collated nails through the floor plate between each stud and into each I-joint below the OSB deck.
4. To prevent the wall from tipping over, brace it at each end using the long 2x4' braces attached to the wall in Step 2 above. Tip the wall out slightly (about ½"), rotate the 2x4 block horizontal at the end of the brace and nail it to the rim board with two 16d duplex nails. Add a second 3¼" collated nail or 16d nail through the brace into the 2x4 block. Secure the top end of the 2x4 brace with another 16d duplex nail.
5. Install turnbuckle pipe braces in the middle sections of the wall for extra support. Install them using three 2" drywall screws into the upper plate and through the floor into an I-joint. Or, screw the brace into 2x blocking secured to two I-joists with 16d duplex nails. Place the braces 10' to 12' apart.

**NOTE:** Do not place a turnbuckle where an interior wall will intersect an exterior wall.

## **5.5. SHEATHING & ERECTING SHORT WALLS**

1. Before erecting the wall, locate the blocking between the rim board and the first/last I-joint to which the bottom plate will be nailed. If not marked on the deck or rim board, go to the basement, locate one of the blocking pieces, make appropriate measurements and transfer to the rim board. The blocking should be on a maximum of 32" centers.
2. After the wall is assembled on the deck (see Section 5.1), align the bottom plate so it is flush with the chalk line along the entire length of the wall. Use a hammer to toenail through the bottom face of the bottom plate into the deck approximately every 6-8' with 8d nails. This will ensure that the bottom plate will be straight before installing sheathing

3. If the House Plan calls for wind bracing in the center of the wall, place a 4x8 sheet of ½” OSB centered on studs and flush with the bottom plate. Tack to the bottom and upper plates with one 8d nail in each corner of the OSB. This will be sufficient to hold the OSB in place while raising the wall but still allow movement when plumbing the corner. Mark all wind-bracing sheets with a large “WB” using red crayon.
4. If one of the short walls is the front wall of the house, the rest of this wall may require sheathing with OSB. Consult the Construction Supervisor to determine if this is the case. If yes, sheathe the entire wall with OSB, ensuring end-of-wall OSB sheets can be properly installed after the wall is raised. Tack to the bottom and upper plates with one 8d nail in each corner of the OSB. Cut pieces to fit below windows. It is not necessary to put OSB above doors or windows.

**CAUTION:** Do not put OSB sheathing or wind bracing on either end of the short walls at this point. This will be done after each wall is erected

5. Attach house wrap to the short walls in the same fashion as that done in Section 5.3.5 but leave the wrap that will go under the end OSB sheathing loose. Fold this part back over the installed sheathing and temporarily tape in place.
6. Install 1” foamboard to any short wall that is not the front wall of the house as was done on the long walls (see Section 5.3.6.). Ensure end-of-wall OSB sheets can be installed properly after the wall is raised. Tape seams and any broken score lines on the foamboard with air sealing tape. If the short wall is the front wall of the house, do not put foamboard over the OSB. This will be done after the wall is raised and after wind bracing inspection (if applicable).
7. Following the procedure in Section 5.4.1, apply two generous beads of air sealing caulk on the deck. Lift the wall and lean it against the long wall braces until it can be joined at the corners. Align the bottom plate with the chalk line. Nail the wall to the deck with two ¾” collated nails through the floor plate into the blocking located in Step 1 above.
8. At each corner, remove the temporary brace on the long wall to allow the walls to come together. Before nailing the corners together, check that the upper plates are flush with each other at each corner. Fasten wall panels to each other by flushing the corners and nailing the adjoining end studs every 12” from bottom to upper plate with ¾” collated nails.

**NOTE:** Be sure both walls are supported before removing the long wall brace on the outside of the short wall

9. When all exterior walls have been erected, plumb and brace all corners with 2x4 bracing on the INSIDE of the house (both long and short walls). Brace with 12’–16’ 2x4s from the upper plate at the corner to the bottom plate. Nail at least once into both the upper and bottom plates with 16d duplex nails for each brace. Keep the top of the brace less than 1” above the upper plate and avoid crossing interior walls with the brace. Add a few extra nails (duplex) where the brace crosses King, Jack, or regular wall studs.

10. Install all OSB wind bracing with 2<sup>3</sup>/<sub>8</sub>" collated nails or 8d nails into each stud and the upper and bottom plate with a maximum 6" spacing.
11. Permanently fasten any tacked, non-wind bracing OSB with 2<sup>3</sup>/<sub>8</sub>" collated nails or 8d nails into each stud and the upper and bottom plate following the Non-Wind Bracing OSB Nailing Pattern described in Section 5.3.4 and shown in Figure 5-1.
12. Unwrap house wrap and staple to each stud.
13. Install ½" foamboard over all OSB, flush on all sides. Nail with 1" button nails following the Foamboard Nailing Pattern described in Section 5.3.6 and shown in Figure 5-2. Tape all seams with air sealing tape.

**CAUTION:** Install ½" foamboard over OSB designated as wind bracing ONLY if wind bracing inspection IS NOT required or inspection has been completed (see Construction Supervisor).

## 5.6. COMPLETING EXTERIOR WALLS

1. Measure and cut 1" foamboard to fit on the exterior of the sill box, **tightly** between the bottom of the wall foamboard and the foundation foamboard. Do the same below any OSB/½" foamboard wall panels. Install the foamboard with 2" button nails about 8" apart and 2" away from the top and bottom seams of the foamboard. Make sure the house wrap is **behind** this foamboard, leaving any extra wrap protruding from the seam between the bottom of the sill box foamboard and the top of the foundation foamboard (see Figure 5-3).
2. As needed, measure, cut, and nail 1" foamboard around porch corners and under the door.
3. Fill in any gaps at the corners.

**NOTE:** These pieces may be too narrow to nail. If so, simply tape in place using flashing tape.

4. After the sill box foamboard has been installed:
  - a. **Tightly** tape the seam between the wall foamboard and the top of the sill box foamboard with air sealing tape, taking care to completely cover the nail buttons above the seam by at least ½". Do not use an additional row of tape to cover the nails below the seam. Covering these nails is not critical.

**CAUTION:** House wrap must extend at least 1" over the surface of the 2" foundation foamboard (see Figure 5-3). If it does not, see the Construction Supervisor.

- b. Continue taping other seams with air sealing tape **except for** the seam between the rim board foamboard and the foundation foamboard. **Do not tape the seam**



**where the house wrap emerges from below the sill box foamboard.** Instead, tape the bottom of the house wrap to the foundation foamboard every 6' with a 3" piece of air sealing tape just to hold it down (see Figure 5-3).

- c. If not already done, fill all exterior corner gaps (both inside and outside corners) with foamboard and tape into place with flashing tape.
- d. At other seams, tape shingle-style, starting from the bottom, beginning with horizontal seams, and overlapping with any vertical seam above. Again, when taping horizontal seams, be sure to completely cover the button nails above the seams as in Step 4a above. Only tape over button nails at the seams (not in the field).

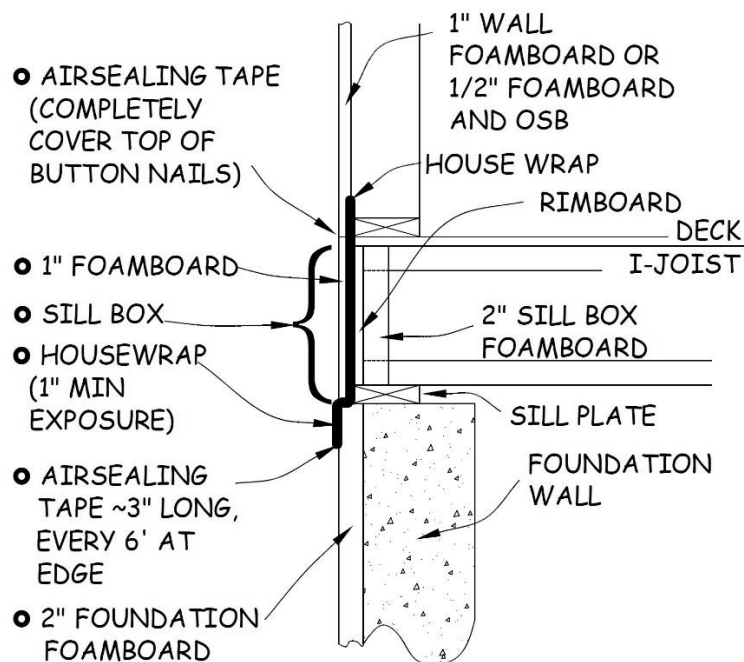

**Figure 5-3. House Wrap and Foamboard Seams.**

5. If not already done, cut out foamboard around windows and doors. Take time to make square cuts to prevent problems during window and door installation.

**NOTE:** To insure square cuts hold saw flat against the jack stud while cutting the foamboard.

6. Fill the inside of every window and door header with 2" of foamboard. Fill any gaps greater than 1/8" with air sealing caulk or spray foam. Cover the perimeter and any joints with flashing tape.

**NOTE:** Use pieces of foamboard that are 1" or 2" thick. This is a good spot to use scraps, as long as the pieces fit together tightly, and the joints of the multiple layers are not aligned with each other.

7. Make sure all L-corner foamboard and all stud/foamboard sandwiches are flush with interior wall studs. Trim if necessary.
8. Do not throw **ANY** foamboard scraps in the dumpster. Set aside in the basement or in black plastic bags.

## 5.7. ***STRAIGHTENING EXTERIOR HOUSE AND ATTACHED GARAGE WALLS***

### 5.7.1. Installing String Line

1. To straighten exterior walls, a VERY taut string line is stretched from one inside corner to another adjacent inside corner and the wall is adjusted to the string line every 8 – 10 feet and braced to hold in place.

**NOTE:** When there is an attached garage, treat the extended house/garage wall as one wall during this process. For straightening walls of detached garages, see Section 23.6 Straightening Garage Walls.

2. For each exterior wall corner, cut a scrap 2x4 10-12” long.
3. Drive a 16d duplex nail straight into the center of this 2x4. Be sure the nail is straight, since the nail above the 2x4 represents the inside of the wall corner. The upper part of the nail will be used to wrap the string line.
4. Place the 2x4 piece on top of the 2x6 upper plates at roughly a 45° angle so that the protruding end of the 16d duplex nail rests tightly against the “inside” corner of the upper plates of both walls (see Figure 5-4).

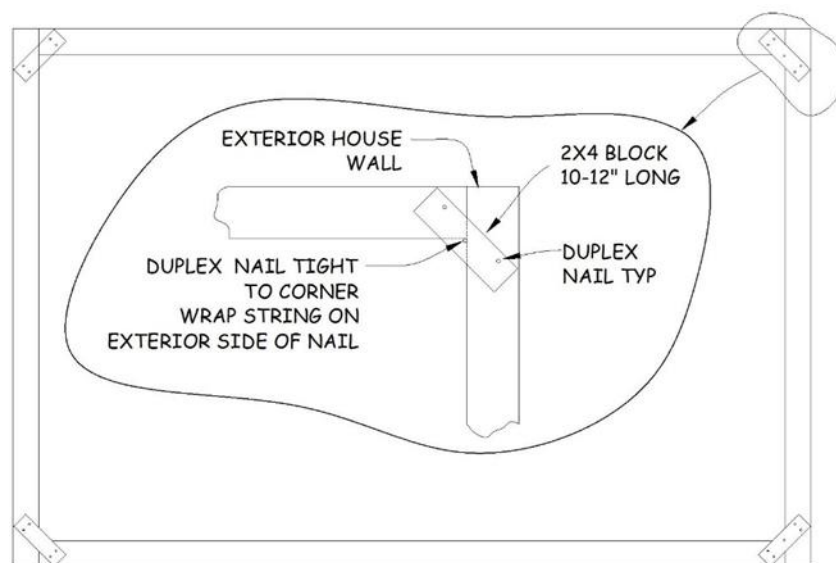

**Figure 5-4. Installing String Line.**

5. Nail the 2x4 to the upper plate with one 16d duplex nail on each end of the 2x4 piece. Nail securely as there will be a lot of tension on these.
6. Repeat steps 4 and 5 at each exterior corner.
7. In the first corner, start the string line on any nail other than the centered nail (feel free to add additional “tie off” nails as needed).
8. Wrap the string line on the exterior side of the protruding centered nail. This should align the string line near the inside edge of the upper plate.
9. Run the string line to the next corner and wrap it around the exterior of the protruding centered nail again. Continue until back to the starting corner. Make sure the string line is not obstructed between corners and is VERY taut.

### 5.7.2. Aligning the String Line to the Wall Corners

1. At each corner, verify that the string line around the corner nail is aligned with the inside of the upper plates. Adjust as necessary using an additional 8d nail to move the string line in or out.

**NOTE:** The string line may not be aligned to the inside of the upper plate all along the wall expanse at this point, but it must be aligned at each corner before straightening the walls between corners.

### 5.7.3. Straightening the Walls

1. Start 5’-7’ from the corner.
2. Place one end of a 6’ level (to be used as a straight edge) against the upper plate and the other against a nearby stud - not the stud immediately below. The level/straight edge should be at a slight angle.

**NOTE:** This “two-point” contact avoids problems with a bowed or twisted stud.

3. Slide the level up the wall until it reaches the string line. If the top of the level moves the string line, use the turnbuckle pipe bracing to move the wall in until the inner edge of the level lines up with the string line. If the level misses the string, move the wall outward until the inside edge lines up with the string line. The wall is now straight in that section. Add more pipe bracing or 2x4 bracing as needed to hold the wall straight.
4. Repeat this at each pipe brace, each interior wall intersection, and every 5’-7’ in between. Add more pipe bracing or 2x4 bracing as needed to hold the wall straight.
5. After straightening the walls the first time, re-check alignment with the string line a second time. Verify that the wall is plumb at each brace and at each intersecting wall location. Compare these readings to those obtained at each corner. If these

readings differ by more than  $\frac{1}{8}$ ", consult with the Construction Supervisor or the Site Leader.

6. After walls are straightened and all bracing is completed, do a final check by sighting along the inside and outside edges of the upper plate of each wall at each corner. Once all walls are straight, remove the string line and the blocks.

## **5.8. FRAMING INTERIOR WALLS**

1. Start by building the longer walls that will intersect the exterior walls. Remove the temporary nails connecting the upper and bottom plates and separate on the deck. Be sure the words "Upper" and "Bottom" remain in the same orientation.
2. If not presorted, select studs for framing walls by sighting along the edge of each stud to determine whether the stud is crowned. If crowned, mark with an arrow pointing to the high side; if not crowned, mark with an arrow pointing to one end of the stud. Do not use studs if they are severely crowned (ask yourself, "Would I use this for my house?"). Place studs with "crown up" and door components in position between plates per markings on upper and bottom plates.

**NOTE:** Set aside the straightest studs for use in the kitchen walls and bathroom tub wall.

3. Make sure the studs are flush with the edges of the plates and that the end studs or corner assemblies are flush with the ends of the plates. Using a plastic speed square with a corner cut off, make a mark on the inside face of each plate at each layout mark to ensure the stud is square to the plate prior to nailing. Align the stud to this mark on the inside of the plate. Nail with two  $3\frac{1}{4}$ " collated nails or 16d nails through the plates into the studs.
4. If the wall is a half-height wall with a  $3\frac{1}{2}$ " x  $3\frac{1}{2}$ " full-height post at the end of the half-height (42") section, the upper plate of the 42"-height section will be  $1\frac{1}{2}$ " short to accommodate the post. If a full-height post is not planned at the end of a 42"-height section, the bottom plate will be  $1\frac{1}{2}$ " short. This will accommodate alternative methods of anchoring the end of the wall to the deck. Studs for a half-height wall are 39" long.

## **5.9. ERECTING FULL-HEIGHT INTERIOR WALLS**

1. Start by erecting the longer walls that intersect the exterior walls. Before erecting these walls, install 2x4 blocking between the two exterior wall studs where the interior wall will be located. Place this 2x4 with the wide side flush with the interior surface of the studs and the top edge 50" off the floor. HAND NAIL with two 16d nails through the studs into the ends of the 2x4.

2. Similarly, where a flush sliding door intersects an exterior wall, install a similar 2x4 block but with the top edge 8 $\frac{1}{2}$ " above the floor. This provides support for the door header at the end opposite that of the single Jack stud.

**CAUTION:** For safety reasons, do NOT use a framing nailer for these first two steps.

3. For walls that do NOT include a flush sliding door, stand each wall section and position the bottom plate in line with the chalk line. Make sure the bottom plate is tight to the bottom plate of the exterior wall and then secure it to the floor using 3 $\frac{1}{4}$ " collated nails if they will hit an I-joist; otherwise, use 2 $\frac{1}{2}$ " deck screws. After checking that the end stud is plumb and tight to the exterior wall, nail at an angle **THROUGH THE EXTERIOR WALL UPPER PLATE** into the interior wall upper plate with 16d nails. Nail the end stud into the blocking installed between the exterior wall studs in Step 1. Check to be sure the joints at the upper and bottom plates are tight.

**NOTE:** If time and staffing permit, consider installing OSB drywall blocking at the end of these walls before they are attached to the exterior wall (see Section 10.5.3.4 for the number and size of the OSB pieces required). Install one piece above and one piece below the 2x4 blocking installed in Step 1 above. Attach the OSB to the end of the wall with three or four pairs of 2" drywall screws, taking care that the OSB does not contact the 2x4 blocking, the bottom exterior plates, or the upper exterior plates.

4. For walls that DO include a flush sliding door:
  - a. Measure the length of the upper plate and cut a 2x4 (or 2x6 if a 2x6 wall) 1 $\frac{5}{8}$ " shorter than that measurement. This will be the top plate for the closet wall.
  - b. Nail that piece to the wall upper plate, extending it 2" beyond the end of the wall upper plate and 3 $\frac{5}{8}$ " short of the interior end (leaving room for top plate overlap).
  - c. Stand the wall up, move it into position with the bottom plate aligned with the chalk line and the door header sitting on top of the blocking installed in Step 2 above. Secure the bottom plate to the floor between the chalk lines using 3 $\frac{1}{4}$ " collated nails if they will hit an I-joist; otherwise, use 2 $\frac{1}{2}$ " deck screws. Tack the loose end of the bottom plate in position with a duplex nail.
  - d. Using a long, straight 2x4 (8' or greater) against the closet upper and bottom plates, plumb the wall and nail the end of the top plate into the exterior wall upper plate with two 3 $\frac{1}{4}$ " collated nails. **Make sure the King/Jack side of the closet wall is plumb and straight.** This will ensure the closet door lies correctly against the wall when installed. (Once an exterior wall top plate is installed adjacent to this closet wall, it will be notched to accommodate the 2" overhang of the interior top plate.)
  - e. Again, place the edge of the straight 2x4 against the side of the closet top and bottom plates. Move the door header against the 2x4 and mark the edge on the horizontal blocking between the exterior wall studs. Nail the header to the wall blocking at this mark with 3 $\frac{1}{4}$ " collated nails

5. Install 2x4 blocking wherever two interior walls intersect and there is no stud at the point of intersection. Place the 2x4 blocking with the wide side flush with the interior surface of the studs of the wall being intersected and the top edge 50" off the floor. HAND NAIL with two 16d nails or two 2½" deck screws through the side of each stud into the ends of the 2x4 blocking.
6. Continue to build the remainder of the interior walls, standing them up, positioning to the chalk line, and nailing into place between each stud using 3¼" collated nails into the I-joist below, or 2½" deck screws where no I-joists are below the wall. Check that each wall is plumb before nailing it to the adjacent wall.
7. When erecting a bathroom tub wall use straight studs. Make sure the tub space measures 60⅞" at the back, the front, and at bottom, top, and middle.

### **5.10. ERECTING HALF-HEIGHT INTERIOR WALLS**

1. Before erecting any half-height (42") walls, install 2x4 blocking between the two exterior wall studs where the wall will be located. Place this 2x4 blocking flush with the interior surface of the studs and the top edge 43½" off the floor. HAND NAIL with two 16d nails or 2½" deck screws through the studs into the ends of the 2x4.

**CAUTION:** For safety reasons, do NOT use a framing nailer for this first step.

2. Run two beads of construction adhesive on the deck, within the chalk lines for the half-height wall, keeping the beads ½" away from the chalk lines. Stand the wall section and position the bottom plate in line with the chalk lines. Make sure the bottom plate is tight to the bottom plate of the exterior wall.
3. Check that the end stud is plumb and tight to the exterior wall, then nail the end stud into the blocking installed between the exterior wall studs in Step 1. Starting at the intersection with the exterior wall, secure the half-height wall to the floor using 2½" deck screws, making sure joints at the upper and bottom plate are tight.

### **5.11. INSTALLING TOP PLATES**

1. Walls must be tied together by nailing overlapping top plates to the tops of all walls. Top plates at the intersection of interior and exterior walls are done first.
2. The top plate on all bearing walls must extend a minimum of 4' on each side of the wall plate joint, and at each corner (see Figure 5-5.).
3. Top plates on non-bearing walls that extend into the 2" notch of the exterior top plates must be at least 16" long.
4. Where interior walls intersect exterior walls, create a notch 2" deep in the top plate of the exterior wall so it can receive the intersecting interior wall top plate. Verify that the interior wall is plumb before locating and cutting the notch.

**NOTE:** Notching 2" deep leaves 3½" of material on exterior 2x6 wall top plates.

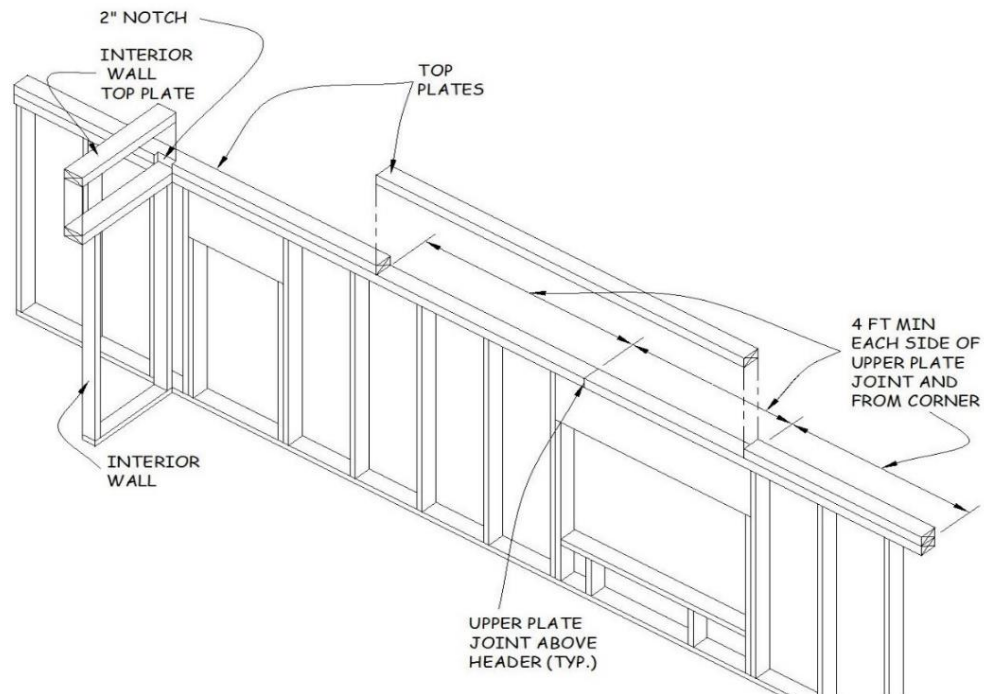

**Figure 5-5. Exterior Wall Top Plate Installation.**

5. To locate the notches, lay the exterior wall top plate on the wall in its final position. Mark the location of each intersecting interior wall. Place the top plate on the deck and, using a speed square, mark lines at each location. Using a circular saw with the blade set at 2" depth, cut the marked edge of the top plate at the outside of each line (this should allow enough clearance for the width of the intersecting top plate). Make multiple cross-cuts between these two cuts and knock the pieces out with a hammer.
6. When nailing top plates, use three 3¼" collated nails or 16d nails across 2x6 plates and two 3¼" collated nails or 16d nails across 2x4 plates. Nail at each intersection of top plates and nail at each stud location. Note that the top plates at an intersection overlap the joints of the walls below (see Figure 5-6).

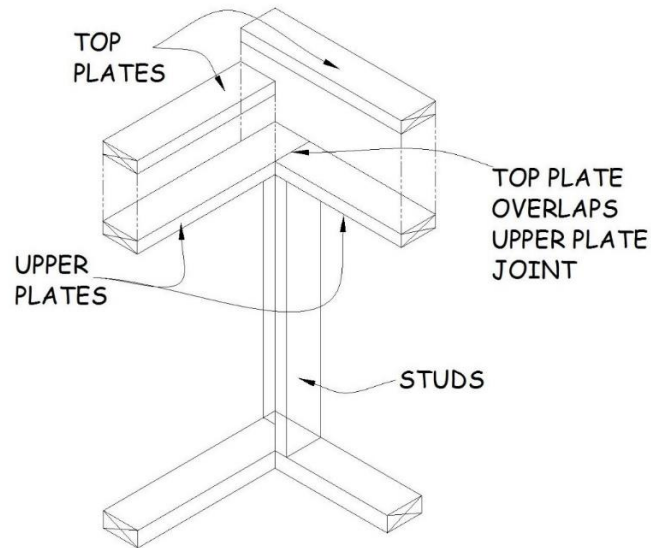

**Figure 5-6. Interior Wall Top Plate Installation.**

7. Nail two to four pairs of nails across exterior door and window headers. Be sure the interior edges of the top plates are flush with the edges of the plates below and that interior walls are tight to exterior walls before nailing.

**NOTE:** Occasionally the house will include a 2x4 interior wall butting against the end of a 2x6 plumbing wall (in a straight line). In this case, install a 2x4 top plate the full length of the wall, on the flush side. Install a 2" wide "filler" on the 2x6 section of the wall (necessary to provide nailing surface for wall sheetrock).