

Chapter 7. Roof Framing

- 7.1 ROOFING PREP WORK
- 7.2 INSTALLING ROOF TRUSSES
- 7.3 INSTALLING PORCH TRUSSES
- 7.4 SHEATHING ROOF
- 7.5 INSTALLING SUB-FASCIA
- 7.6 BUILDING AND INSTALLING SCUTTLE BOX
- 7.7 INSTALLING LATERALS AND X-BRACING
- 7.8 INSTALLING L-CLIPS

Tools needed by volunteers:

Hammer
Nail apron
Tape measure
Square
Utility knife
Pencil

Tools and equipment needed:

Generator
Extension cord
Circular saw
Reciprocating saw
Air compressor
50' tape measure
6' level
[Framing nailer](#)
Impact driver with bits
Truss lock
Sledge hammer
Pipe clamp
Framing square
Chalk line
String line
Plank
Ladder

Materials needed:

Roof trusses
1" Foamboard
4x8' ½" OSB
2x4 Lumber
2x6 Lumber
16d Nails
8d Nails
[3¼" Collated nails](#)
[2⅜" Collated nails](#)
4" & 6" TimberLok® screws
H-clips
L-clips
[House wrap](#)
[Air sealing tape](#)

Personal Protection Equipment:

Fall protection harness (required)
Safety glasses (required)
Hard hat – below roof (required)

[Reference Materials:](#)

[House Plan](#)

Safety First! Review the Safety Checklist before performing tasks in this chapter.

7.1. ROOFING PREP WORK

7.1.1. Installing Planks and Gable End Blocking

1. Install a plank along the center of the house for the center truss installer to walk as trusses are installed. The plank is installed on top of interior door headers and other bracing as required. This is a 24' plank that starts at one end of the house and will be moved to the other end as the truss installation progresses. The plank needs to be supported at three points in either location.
2. Install 2x6 blocking along the top of both gable end walls (continuous along the entire length) with 16d (or 3¼" collated) nails staggered every 12". Hold the 2x6 back 1" from the outside of the top plate (using a piece of 1" foamboard as a guide works well). The 2x6 overhangs the plate on the interior side of the wall and serves as sheetrock blocking.
3. Install 2x4 blocking along the top of the porch gable end framing, holding the blocking 2" back from the outside face of the framing. Nail with 16d (or 3¼" collated) nails staggered every 12".

7.1.2. Gable End Truss Prep

7.1.2.1. Building Gable Ladders

1. The steps that follow describe building a ladder to form gable roof overhangs. A "ladder" is built using 2x6s. The sub-fascia is the "outside" leg of the ladder, another 2x6 is the inside leg, and 2x6 blocks 6" long are used as rungs.
2. Measure from the peak of each gable end truss to the tail. This is the total length of the sub-fascia. Check the roof pitch on the House Plan (the garage roof pitch may not be the same as the house roof pitch). Cut long 2x6 pieces for the SUB-FASCIA to match the length and angle (4/12 pitch = 18.4°; 5/12 pitch = 22.5°; 6/12 pitch = 26.6°) of the top chord of the gable truss and mark them for location. DO NOT use material with a pronounced crown. Since two pieces of 2x6 are usually needed, make sure to seam the two pieces, with a butt joint, in the middle of a double sub-fascia spacer block.
3. For both gable end trusses, and the porch gable truss (if required) - cut INSIDE 2x6s to match the sub-fascia length above less 32", with an angle cut on the peak end to match the roof pitch. These pieces will go against the truss **OSB** once the ladder is completed. Lay the inside 2x6 on a corresponding sub-fascia 2x6, with the angled ends and top edges flush. From the peak of the matched angle cuts, measure and mark the top edges of the 2x6s for sub-fascia spacer blocks. The first mark is at 5" and then every 32", with the last one flush with the square end of the inside 2x6 (not necessarily at 32"). At each mark, put an X on the edge of the 2x6 toward the eave end. Make a mark for a double block (if required) where the butt joint of the 2x6 sub-fascia will be located.

4. Count the number of marks made on all three trusses. Cut that many 2x6x6" sub-fascia spacer blocks (using scrap).
5. For each gable end truss, assemble the blocks and inside 2x6s from Steps 2 through 4 above. Align one end of the block with the layout mark and flush with the edges of the inside 2x6. Nail together using two 3/4" collated nails through the long inside 2x6 into the end of each block (similar to building a stud wall).

NOTE: Each gable requires a right and a left hand "ladder"; be sure to assemble each "ladder" with the inside 2x6 arranged in the correct orientation.

6. Set the partially assembled ladder aside until the gable ends are covered with foam. Finish installing the ladders in Section 7.1.2.2.4, below.

7.1.2.2. Gable Truss Prep

1. If the truss top chord is a 2x6, the bottom end of the tail must be trimmed to allow later installation of the gable corners. Trim the tails by measuring vertically up the tail 2" from long point, marking a line square to the tail end and cutting along the line.
2. Install the pre-cut 18" wide roll of house wrap the length of the bottom chord of the gable end truss. Snap a chalk line 3 1/2" above the bottom of the bottom chord, and staple the top edge of the house wrap along the line.
3. Cover the factory-installed OSB on all gable trusses by stapling house wrap shingle style, overlapping each layer 2". On the face of the house wrap, mark and draw a line at the locations of the vertical gable end truss chords using a Sharpie or other marker. This will ease later siding installation.
4. Attach the inside 2x6 side of the "ladder" built in Section 7.1.2.1 to the top chord of the gable end truss with a 3/4" collated nail midway between each 6" block, keeping the top edges flush and the angled end aligned with the truss peak. Then, add a pair of 3 1/2" screws through the inside 2x6s into the truss top chord between each block and at each end. Finally, align the peak end of the sub-fascia 2x6 to the gable peak, and nail it to the blocks using two 3/4" collated nails into each block.
5. Nail the sub-fascia ends to each other at the peak using 3/4" collated nails. Keep the face and peak aligned when nailing.
6. On one side of the center vertical truss chord, and as close to the top as possible without cutting into the truss framing, cut an opening in the OSB with a 4" hole saw for a crane lifting sling to be inserted.

7. After the truss is covered with house wrap, fold the bottom chord house wrap back toward the top of the truss and secure it with a few pieces of air sealing tape. This ensures it will not be in the way during installation of the truss.
8. On the inside face of the top chord of the non-zero end gable truss, nail scrap 2x4s using 3¼” collated nails every 12” from the peak down to both tails of the truss.

NOTE: Since the spacing between this truss and the one next to it is more than 24” o.c., this extra 2x4 provides the correct spacing to support the roof sheathing. This extra 2x4 is NOT REQUIRED for a detached garage.

9. If there is a gable end porch with a roof common with the house, lay one of the porch trusses on the house porch-end gable truss. Align the top chords and tails on the appropriate end of the truss. Use a marker to draw a line on the face of the house gable truss along the opposite top chord of the porch truss. This line will be used to locate a 2x4 to support the roof sheathing installed in Section 7.3.6, if required.

7.1.3. Installing L-Braces

1. L-braces are used to support the gable-end truss at each end of the house during installation, and should be located within 2’ of the center plank installed in Section 7.1.1. They **must be installed so that they don’t interfere with the sub fascia** when the truss is tipped up into position. L-braces are attached to a wall stud for adequate support.

NOTE: If there is a gable end porch, the L-brace must be installed far enough away from the porch frame so it doesn’t interfere with installation of the porch trusses.

2. To determine the correct height of the L-brace above the top plate, locate a wall stud within 2’ of the center plank location, mark the stud for future reference, and locate it on the exterior of the house. Measure the distance to it from the outside corner of the house.
3. Take that measurement to the truss to be used on that gable end, and measure that distance from the heel and make a mark. Then, at that mark, measure the vertical distance from the bottom of the bottom chord to the top of the top chord. Subtract 16” (to ensure adequate clearance for the gable sub-fascia) and mark the L-brace that distance from the top end.
4. Install the L-brace at the stud marked earlier, with the 2x6 face against the wall and the mark from Step 3 above even with the top of the top plate. Double check the height of the top of the L-brace above the top plate, and attach it to the wall using two Timber screws into the stud about a foot above and below the mid-height of the stud. At the top plate, slide a ¼” spacer between the L-brace and wall foamboard,

just below the top edge of the foamboard (to ensure adequate space for the bottom chord) and run three 6" Timber screws into the upper and top plates (one in one, two in the other). Finally, install one more screw into the rimboard.

7.1.4. Marking Wall Top Plates for Trusses

1. Beginning at the zero end, mark the locations of the trusses on the top plates of both eave walls 24" o.c. Confirm that the truss markings are positioned such that the truss is bearing completely over a stud or header.
2. At the opposite end of the zero corner, the measurement from the last common truss to the gable end truss will be more than 24" o.c. Mark the INSIDE-TO-INSIDE measurement between these trusses on the top plate - it will be used when sheathing the trusses.

7.1.5. Bracing Prep

1. For lateral bracing, select enough long 2x4's to total twice the length of the house plus an additional 2' for EACH overlap. If the house is 30' wide or wider, increase the amount to three times the house length, plus overlap. Mark them as laterals and set aside.
2. For X-bracing, select eight 2x4's, each at least 12' long, and cut an approximate 20° angle on both ends. Orientation of the angle is irrelevant. Mark them as X-bracing and set them aside with the lateral bracing.
3. The first common truss on each end will require a temporary 2x4 spacer. Locate two scrap 2x4s, each about 30" long. On one piece, mark two lines 24" apart to use for the Zero End spacer. For the Non-Zero End, locate the measurement noted on the top plate from Section 7.1.4, and place marks that distance apart on the other 2x4 scrap.
4. Both gable end trusses will require diagonal bracing prior to setting the other trusses. At each interior end of the house, place one stud-length 2x4 and one 12'-16' 2x4.

7.2. INSTALLING ROOF TRUSSES

1. **HARD HATS ARE REQUIRED ON ANY GROUND CREW.**
2. Trusses are secured to the top plate with 6" Timberlok® screws. At each truss location, begin a 6" Timberlok® screw in the joint between the top of the stud and the upper plate. The screw should be 20-30° from vertical and about 2-3" into the upper and top plates without going through. Be sure the screw does not protrude through the top plate surface.
3. Stand the first gable truss into position on the walls and against the L-brace.

4. On each end of the truss, measure from the top plate to the end of the truss tail. Be sure the measurement is to the outside edge of the LONG WALL top plate, not the end of the short wall top plate. If the short wall top plate is not flush with the end of the long wall top plate, adjust the measurement accordingly. Move the gable truss so that the overhang measurement is the same on each side (for example: 22¼" on each side).
5. With the truss tight down against the top plate and blocking, attach the truss to the L-brace support using two 4" TimberLok® screws about 12" apart so it cannot fall back on the installers. Checking that the truss is still down tight to the top plate, screw 4" TimberLok® screws through the bottom chord into the blocking or top plate every 2'-3' until the bottom chord is tight to the blocking.
6. Repeat for the other gable truss. Measuring from the top plate at the back of the house (the back, since it usually has an unobstructed run for a string line) to the truss tail, locate the truss at the same distance as the other gable truss. Since the overall truss length may vary slightly, measure only that end.
7. Nail a 2x4 block to the measurement (back) end of each gable truss, then run a taut string line from one gable truss tail to the other. As the common trusses are set in place, use a 2x4 gauge block between the tail end and the string line to locate each truss.
8. Stand the first common truss in place, maintaining the appropriate distance from the tail end to the string line. Holding one end of the truss tight to the top plate and aligned with the layout mark, run the pre-started Timberlok® screws into the bottom chord until the head is countersunk below the interior framing surface. Repeat at the other end of the truss.
9. Install the 2x4 pre-nailed spacer prepared in Section 7.1.5.3 near the peak of the gable and common truss. The space between the gable truss and first common truss is to be the same as that measured between the two at the top plates. This secures the trusses together with the proper spacing and holds the trusses from tipping during installation.
10. Nail one end of a 2x4 near the top of the gable truss down through the first common truss and nail the bottom end to an interior wall top plate after the gable truss is plumb. Locate the lower end of the diagonal support so that it does not interfere with the bottom chord of the next truss. This safety measure ensures the trusses cannot tip back into the house while truss installation continues.
11. Install all common trusses as in Step 8 above. Use the metal truss-lock braces to secure the peak of each truss. These braces will also ensure maintenance of 24" o.c. spacing.
12. When 50-75% of the trusses are installed, slide the lateral and X-bracing prepped in Section 7.1.5 into the trusses.
13. Lean four remaining trusses against the gable end truss and secure them to prevent them from falling. Continue with installation of the remaining common trusses.

7.3. **INSTALLING PORCH TRUSSES**

1. Porch trusses are to be centered front-to-back on the porch framing. Locate the center of the porch framing and measure 12” in each direction to locate the center of the middle two porch trusses. Continue 24” o.c. spacing in each direction as required.
2. If not already completed, use 16d or 3¼” collated nails to secure 2x6s to the outside faces of the porch framing, keeping top and bottom edges flush.
3. Nail pieces of scrap 2x4 to the top of the front porch framing spaced 2” back from the front face to serve as blocking for the porch gable truss bottom chord.
4. Make certain house wrap has been attached to the gable porch truss sheathing.
5. Install the first porch truss on the truss layout mark. If one end of the porch trusses lines up with the house trusses, align the gable truss tail with the house truss tails by sighting along the house trusses, or by using a straight 2x4 as a straight edge. If the porch roof does not have a surface common with the house roof, center the trusses side-to-side on the porch framing.
6. The remaining porch trusses are installed at the 24” layout marks and the gable porch truss is set in place with the OSB sheathing flush with the outside face of the front porch framing. Secure the trusses with 6” TimberLok® screws through the porch framing into the truss bottom chord.
7. On houses with a porch at the gable end and with no truss against the house gable truss, a 2x4 must be nailed against the house’s gable truss, aligned with the line marked in Section 7.1.2.2.9, to support the edge of the porch roof sheathing.

7.4. **SHEATHING ROOF**

7.4.1. **Cutting Full-Width Row OSB Roof Sheathing**

1. Refer to Figure 7-1 and Figure 7-2, below, which show examples of the roof sheathing layout for a 36’ and 30’ long roof, respectively. Note that each **odd** row has a **34” piece** at the zero end, and each **even** row has a **58” piece** on the zero end. Also, note that the **bottom row** is not full-width. The size of these **bottom row** pieces will be determined in Section 7.4.2.
2. Determine the non-zero end pattern, and the number of full and half-sheets. Using a large marker or crayon, write the number and size of the end pieces required on the eave side of each corner of the house. The zero end will always require two each of the 34” and 58” pieces; the non-zero end will require two each of 62” and 38” pieces. Also, write the number of full and half-sized pieces near the middle of the house where the sheets will be staged for lifting onto the roof.

- Cut four full sheets into 34"/62" pieces, and four more sheets into 38"/58" pieces. Label each piece with the size, using a red crayon.

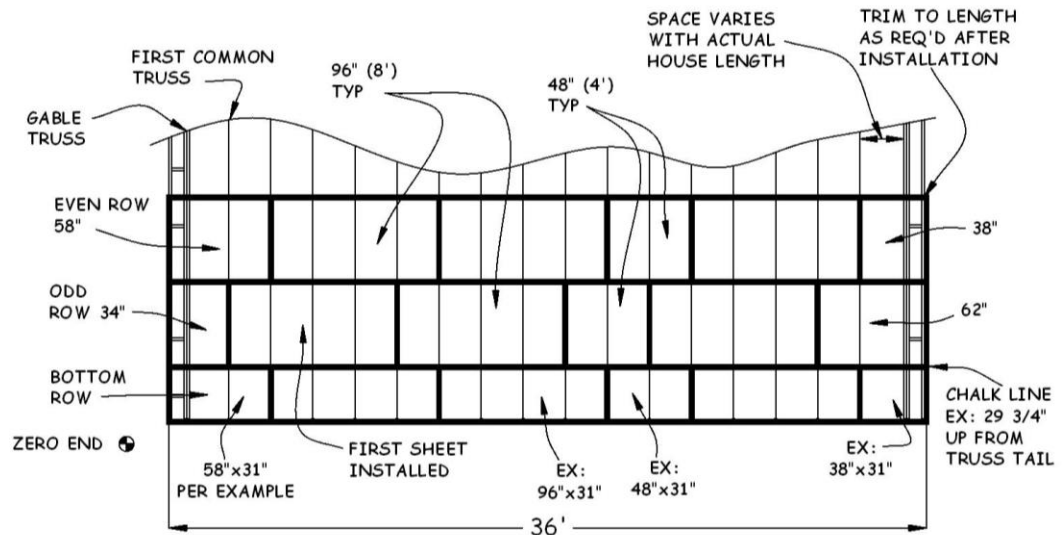

Figure 7-1. OSB Layout for 36' Roof.

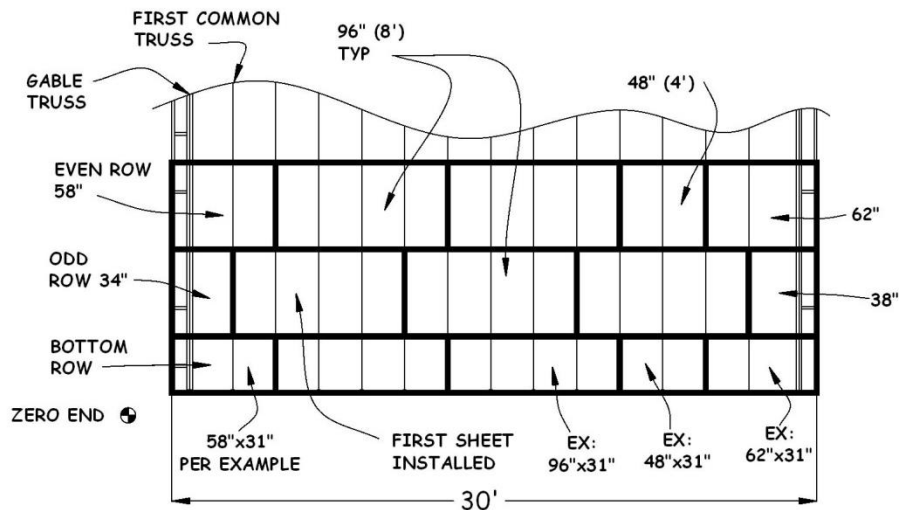

Figure 7-2. OSB Layout for 30' Roof.

- Place two 34" and two 58" pieces on each eave side of the house at the zero end, and two each of the 38" and 62" pieces on each eave side of the non-zero end. There are typically 4 rows of sheathing on each side of the house, or 8 rows total. As shown in Figure 7-1, Figure 7-2, and Table 7-1, the 62" and 38" pieces are used on the non-zero end, but not necessarily in the same row as its corresponding cutoff.

Table 7-1. OSB Roof Sheathing Cut List Worksheet.

Total Roof Length*	Odd Rows				Even Rows				Totals for 4 Full Width Rows	
	Zero End	Full Sheets	# of "4s" Req'd	Non-Zero End	Zero End	Full Sheets	# of "4s" Req'd	Non-Zero End	Total # of Full Sheets	Total # of 4s
20	34	1	1	62	58	1	1	38	8	8
22	34	2	0	38	58	1	1	62	12	4
24	34	2	0	62	58	2	0	38	16	0
26	34	2	1	38	58	2	0	62	16	4
28	34	2	1	62	58	2	1	38	16	8
30	34	3	0	38	58	2	1	62	20	4
32	34	3	0	62	58	3	0	38	24	0
34	34	3	1	38	58	3	0	62	24	4
36	34	3	1	62	58	3	1	38	24	8
38	34	4	0	38	58	3	1	62	28	4
40	34	4	0	62	58	4	0	38	32	0
42	34	4	1	38	58	4	0	62	32	4
44	34	4	1	62	58	4	1	38	32	8

*Total Roof length = Plan House length + 2 feet

5. Depending on the length of the house, a 4' piece may also be needed in the middle of the row to reduce scrap and to maintain the stagger of the joints between sheets. In the 36' example in Figure 7-1, a 4' piece is required in each row. Figure 7-2 shows a **4' piece in even rows only**. Referring to "**Total # of 4s**" in Table 7-1, determine the number of 4' pieces required. Cut full-width sheets in half to obtain the required number, label with the size, and place half of them on each eave side of the house near the middle.
6. Referring to "**Total # of Full Sheets**" in Table 7-1, determine the number of full sheets required. Place half of this number on each eave side of the house near the middle.

7.4.2. Planning OSB Roof Sheathing

1. Roof sheathing is installed with a 1¼" overhang past the truss tails. At the peak, a 2" opening is required for adequate attic ventilation. Any non-full-width row must be located at the bottom of the roof so the sub-fascia can provide adequate support. The following describes how to determine the number of rows of full-width (FW) sheets, the width of the bottom row, and the location of the chalk line to mark the bottom of the first FW row.
2. Determine the number of rows of sheathing required by measuring the length (in feet and inches) of a truss top chord. Subtract the nearest lesser multiple of four from the feet portion. Divide the multiple subtracted above by four; the result is the number of FW rows. Subtract 2" from the remainder; the result is the location of the lower edge of the first FW row, measured up along the top edge of the truss tail. Then add 1¼" to this number to get the width of the bottom row (see Example in Table 7-2).
3. Use Table 7-1 to determine the number and sizes of sheets required for the appropriate length even row, and, for each side of the house, cut that number to the width calculated in Step 2.
4. Measure up from the tail and mark the location of the chalk line (bottom of first FW row) on each gable truss. Snap a chalk line from these marks across all the trusses. This line is the guide for the installation of the bottom edge of the first full-width row of OSB sheathing.

Table 7-2. Example Roof Sheathing Calculations.

18'-7¾"	Length of truss top chord
- (16'-0")	Subtract nearest lesser multiple of 4; 16 ÷ 4 = 4 FW rows
<u>= 2'-7 ¾"</u>	Remainder
- 2"	Subtract 2" – Ventilation gap at peak
= 2'-5¾"	Bottom of 1 st full-width row, chalk line location (29¾")
+ 1¼"	Add 1¼" - amount sheet overhangs eave sub-fascia
<u>= 2'-7"</u>	Width of bottom row (31")

7.4.3. Installing OSB Roof Sheathing

1. For the first row, install a full-width 8' long piece of OSB with the bottom edge aligned with the chalk line and one end centered on the second truss from the zero end. With 8d nails, nail the bottom corner of the sheet at the second truss, then check the alignment of the bottom edge with the chalk line, center the other end of the sheet on its truss, and nail that bottom corner. At the top of the sheet, align the corners with the centers of their trusses and nail. Measure from the edge of the second truss and mark on the upper edge of the sheet every 24". Adjust each truss to its mark and nail.
2. Repeat for each subsequent sheet, nailing the top of the sheet only. Align one top corner with the adjacent sheet, leaving a $\frac{1}{8}$ " gap between sheet ends, and the diagonally opposite corner with the chalk line at the bottom. Nail the top corner adjacent to the previously installed sheet. Center the other top corner on its truss, recheck the alignment of the bottom with the chalk line, and nail the top corner. Measure the 24" truss spacing from a nailed truss that is not at a joint between sheets. Nail into each truss along the top of the sheet with 8d nails. DO NOT nail the bottom of the sheet at this time, since the tails will need to be straightened and spaced correctly before nailing. The sheet is secure so there is no need to nail any more than this at this time.
3. Before nailing the OSB at the gable end truss, be sure the gable truss is straight. At the wall top plate, measure between the gable truss and the adjacent common truss, and maintain that spacing between the gable truss and adjacent common truss for each sheet of OSB installed. As a check, have the ground person sight along the gable truss, since the adjacent truss may not be straight.

NOTE: The distance between the zero end gable truss and the first common truss is $21\frac{3}{4}$ ". The distance between the last common truss and the non-zero gable end truss is more than 24" and will depend on the actual house length.

4. Before proceeding with the installation of additional sheathing rows, use 16d duplex nails (one nail per truss) to fasten a row of 2x4s along the entire length of the first row, 6" up from the bottom edge of the first sheets, to serve as a stop for tools, material, and personnel.
5. Place H-clips on the OSB between each truss and start the second course (row) using the OSB piece cut earlier to stagger the OSB joints.
6. Finish nailing the sheets using $2\frac{3}{8}$ " collated nails on every truss – seven nails on the edges and five in the field intervals. Check under the sheathing to make sure the nails hit the trusses.
7. Before nailing the OSB at the gable edges, sight along the gable sub-fascia and straighten as required, then nail the OSB edge into the sub-fascia using the prescribed pattern.

8. If the OSB extends beyond the gable end sub-fascia, trim the edge flush to, or up to ¼” short of, the outside face of the sub-fascia. Locate and mark the sub-fascia face on the OSB and snap a chalk line. Cut using a circular saw set to ½” depth.

7.5. INSTALLING EAVE SUB-FASCIA

1. On the eave side of the house, position a long 2x6 sub-fascia, crown up, tight to the underside of the sheathing. Extend one end flush to the outside face of the gable end sub-fascia, making sure the other end is centered on a truss tail. Cut to length as required. Nail the 2x6 to the ends of each truss with two 16d nails. Repeat at the other end of the eave side and then fill in between them until the eave is finished.
2. From the ground, sight along the eave sub-fascia and straighten the sub-fascia as required for appearance. Take extra time to do this. A straight piece of fascia will look better against the gutter, while crooked or wavy sub-fascia will stand out.
3. Once the sub-fascia is straight and true, nail the OSB to the eave sub-fascia using 8d nails on 8” intervals.

7.6. BUILDING AND INSTALLING SCUTTLE BOX

7.6.1. Building Scuttle Box

1. Typically, the scuttle box is pre-built and delivered to the site prior to the day it is to be installed. However, if it has not been built, use the following instructions to build one. See Figure 7-3 for a picture of the finished scuttle box and Figure 7-4 and Figure 7-5 for schematic drawings.



Figure 7-3. Scuttle Box.

2. Cut four pieces of OSB: two sides, each 32" wide by 19³/₄" high and two ends, each 25¹/₂" wide by 19³/₄" high.
3. On the smooth face of the OSB end pieces, draw a line 16¹/₂" down from the top edge. Find the centers of the two 25¹/₂" edges and draw a line on the rough face between them. Then draw two parallel lines on either side of the centerline 11¹/₄" from it to locate the inside edge of the 2x2s.
4. On the smooth face of the side pieces, locate the center of the two 32" edges, and draw parallel lines 14" to each side of that centerline. These lines will be used to locate the inside edge of the end piece at assembly.
5. At the bottom (non-factory) 25¹/₂" edge of each end piece, cut a notch 1⁵/₈" wide by 3³/₈" high in the two corners. This leaves a tab 22¹/₄" wide at the bottom that will fit with a 1/4" clearance between the truss bottom chords.

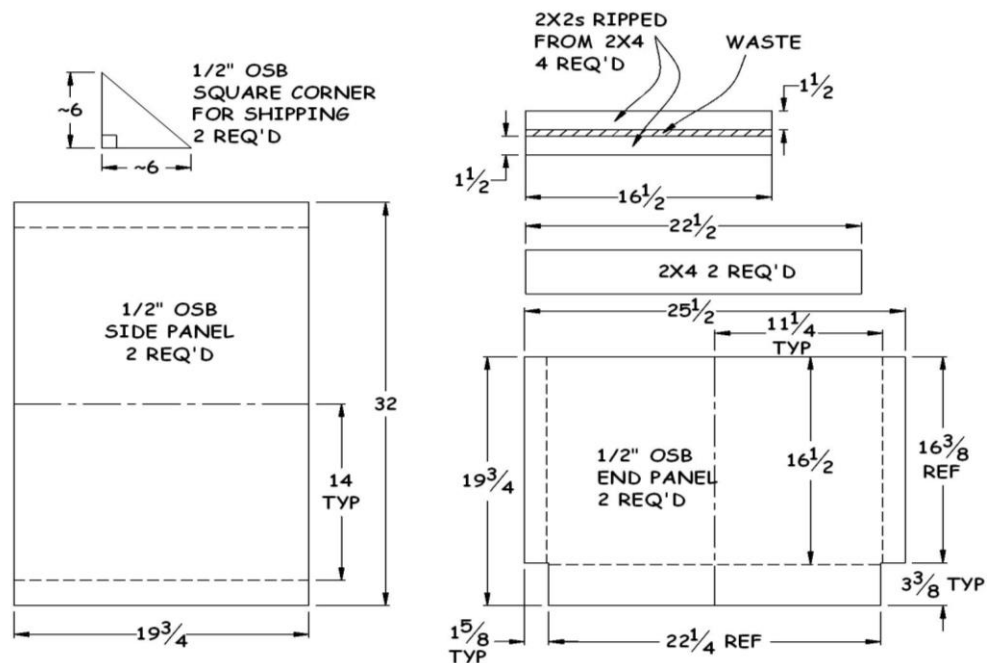

Figure 7-4. Scuttle Box Cut Diagram.

6. Cut two 2x4s 22¹/₂" long and two 2x4s 16¹/₂" long. Mark a centerline on the longer pair at 11¹/₄" from each end.
7. Rip each 16¹/₂" piece into two 2x2s (1¹/₂" square).
8. On each OSB end piece, attach one of the 2x4s to the smooth face at the 16¹/₂" line and with the centerlines aligned using a pair of 1⁵/₈" screws at each end and a pair in the middle. Check that the 2x4 extends below the OSB bottom edge, and that the 2x4 ends are slightly beyond the edge of each notch.

- On the rough side of each end piece, attach a 2x2 even with the top of the 2x4 (flush with the top of the OSB) and aligned with the vertical line drawn earlier. Attach with 1⁵/₈" screws, one at each end and one in the middle.

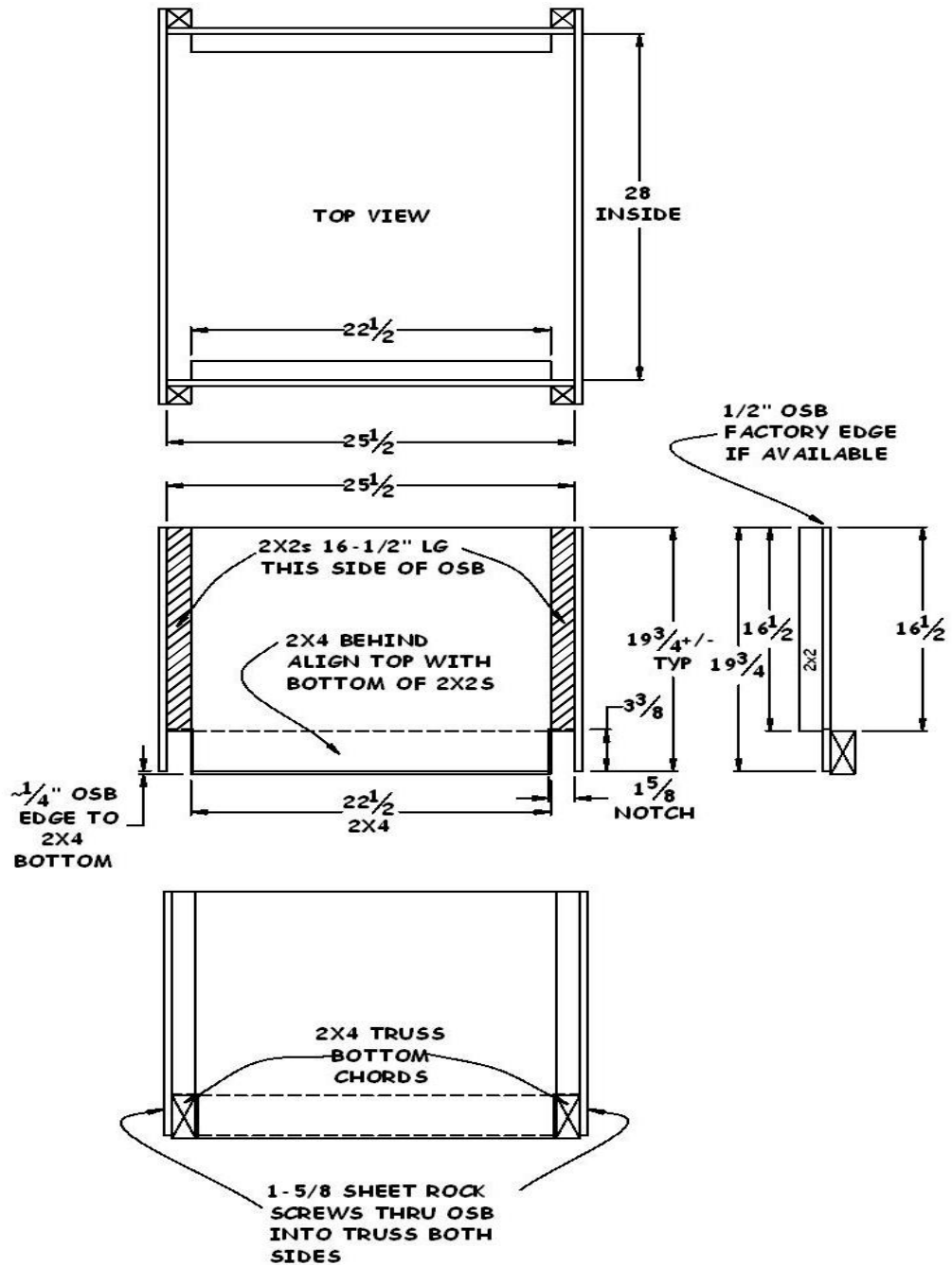

Figure 7-5. Scuttle Box Assembly.

- Assemble the scuttle hole by setting the factory edges of the two sides and two ends on a level surface to ensure that the top edges of the box will be flush with each other.

11. With all smooth sides facing inward, align the end piece 2x2s with the vertical lines on the sides, and screw the sides to the 2x2's using 1 $\frac{5}{8}$ " screws, three in each joint. Keep the box square as the connections are being made.
12. Check that the box is square, place the square shipping corners tightly in two diagonally opposite corners atop the 2x4, and screw in place.

7.6.2. Installing Scuttle Box

1. Lift the box (side-wise) into the attic and place it between the trusses in the location specified in the House Plan. Slide the assembled box along the trusses to optimize ease of access and clearance above.
2. When the scuttle box is located in a bedroom, line up one end of the scuttle box with the wall surface above the swinging door, so the wall rock above the door can extend up into that end of the scuttle box.
3. When the scuttle box is located in a closet or pantry (typically at the end of stairs) keep the edge of scuttle box nearest the swinging door 4" from the wall surface above the door to leave a little room for the wall mounted light fixture that goes above the door in the closet or pantry so it doesn't interfere with attic access.
4. Position the bottom of the scuttle box 2x4s flush with the bottom of the trusses and screw the bottoms of the side pieces to the truss cords with 1 $\frac{5}{8}$ " screws, four on each side. Using 16d nails, nail through the OSB and truss chords into the ends of the scuttle box's 2x4x22 $\frac{1}{2}$ " cross-pieces.
5. Remove the square shipping corners and give them to the Construction Supervisor.

7.7. INSTALLING LATERALS AND X-BRACING

7.7.1. Installing Lateral Truss Bracing

1. After trusses have been installed, nail two to three rows of long 2x4 lateral bracing across the tops of the bottom chords of the trusses with two 16d nails at each truss held to a 24" spacing for ceiling sheet rock installation. Lateral bracing can be spaced a maximum of 10' apart.
2. Check the location of the scuttle hole before installing the bracing. The bracing or location of the scuttle may need to be adjusted to prevent the creation of problems later.
3. Starting at one end, measure the distance at the top plates between the end truss and the first truss. In the center, set the first truss at this distance and nail the bracing to the outside end of the top plate and the first truss. From the first truss, measure and place a mark along the entire lateral brace so trusses will be spaced on 24" centers.

Nail each truss in place with two 3¼” collated nails, making sure the trusses are spaced 24” o.c.

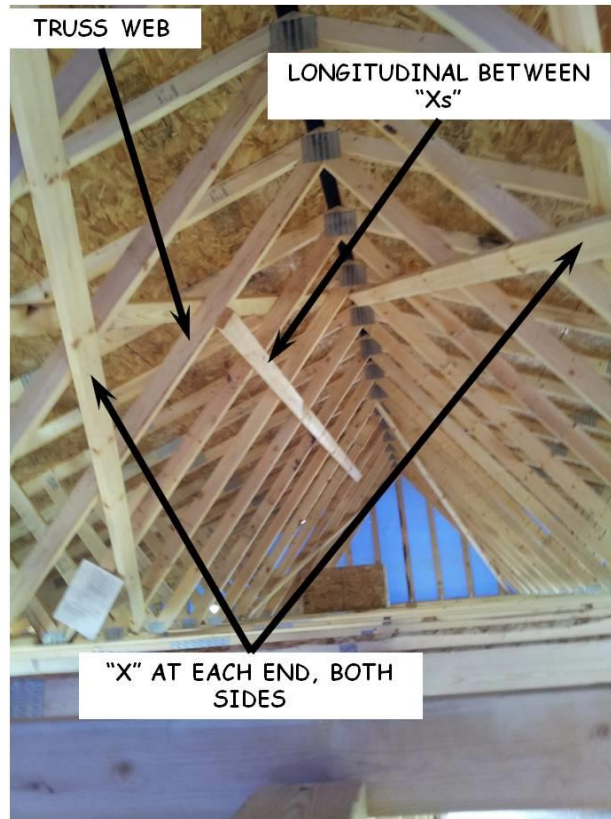

Figure 7-6. Truss Bracing.

4. When a second piece of 2x4 is needed, make certain that the lap spans back two trusses and continue the installation. Make certain that the installation runs parallel to the exterior wall to ensure the bracing is perpendicular to the trusses to ensure a square installation and 24” centers between all trusses.

7.7.2. Installing X-Bracing

1. After roof sheathing has been installed, permanently install X-bracing (diagonal). This bracing prevents lateral movement of the truss system. The bracing is nailed to the truss webs as shown in Figure 7-6.
2. X-bracing uses 2x4's with ends cut to 22.5°. Install pairs of X-bracing at each end of the house. First, nail one 2x4 on the lower edge of the truss web, with one end butted up to the inside face of the gable end truss at the peak, and the other end at the top edge of a bottom truss chord (wherever the end falls). Using two 3¼” collated nails at each intersection of brace and web, nail the 2x4 from the peak of the gable end truss diagonally down the lower side of the common truss webs. Make certain the bottom end of the brace does not extend below the bottom truss chord or it will conflict with ceiling sheet rock installation later.

3. Nail a second 2x4 on the upper side of the same set of truss webs on the opposite diagonal forming an “X” with the first brace.
4. Repeat these steps on the remaining three corners of the house.
5. Connect the X-braces by nailing one long 2x4, horizontally, to the truss webs, about halfway down from the peak. Each end of the longitudinal bracing must be nailed to at least two truss webs to which an X brace is nailed (see Figure 7-7). If more than one longitudinal 2x4 is required to span the distance, overlap at least two trusses where they meet.

7.8. INSTALLING L-CLIPS

1. Install an L-clip at each point where a roof truss intersects with an inside wall top plate. The purpose is to hold the two firmly in place.
2. Plumb free-standing walls before installing L-clips.
3. Using joist hanger nails, fasten the shorter side of the clip to the top plate.
4. Fasten the longer side of the L-clip (the one with the slot going up) by tightly nailing a joist hanger nail at the top of the slot.