

Chapter 23. Garage Construction

23.1 ESTABLISHING CHALK LINES

23.2 MEASURING AND CUTTING WALL PLATES

23.3 MARKING WINDOW & DOOR LOCATIONS ON EXTERIOR WALL PLATES

23.4 MARKING STUDS ON EXTERIOR WALL PLATES

23.5 ERECTING GARAGE WALLS

23.6 STRAIGHTENING GARAGE WALLS

23.7 INSTALLING TOP PLATES AND SHEATHING WALLS

Tools needed by volunteers:

Hammer
Nail apron
Tape measure
Square
Pencil

Materials needed:

2x4 studs
4x9 x ½” OSB
16d nails
16d duplex nails
8d nails
¾” Collated nails
⅔” Collated nails
6” TimberLok® screws
Sill seal

Tools and equipment needed:

Generator
Extension cord
Circular saw
Chop saw
Saws-all
Drill driver
Framing nailer
6’ level
4’ level
Framing square
Chalk line
Pry bar
String line
Stepladder

Personal Protection Equipment:

Safety glasses (required)

Reference Materials:

Garage Plan
Plate Layout Drawing

Safety First! Review the Safety Checklist before performing tasks in this chapter.

23.1. ESTABLISHING CHALK LINES

1. When laying out lines on the garage foundation, use a process similar to that for laying out lines on the house foundation (see Section 1.1).
2. With a detached garage, at each of the four corners, measure in $3\frac{1}{4}$ " from the outside of the foundation wall and make a mark. Proceed to Step 4 below.
3. With an attached garage, at the wall common with the exterior house wall, determine the location of the outside of the house framing, measure 5" in toward the garage interior and make a mark on the curb where it touches the house wall (see Figure 23-1). This establishes Point 1. Measure from Point 1 to the outside of the curb. Establish Point 2 at the other end of the garage wall by measuring that distance in from the outside of the curb, and $5\frac{1}{4}$ " in from the front of the garage curb. Establish Points 3 and 4 as shown in the Figure 23-1.

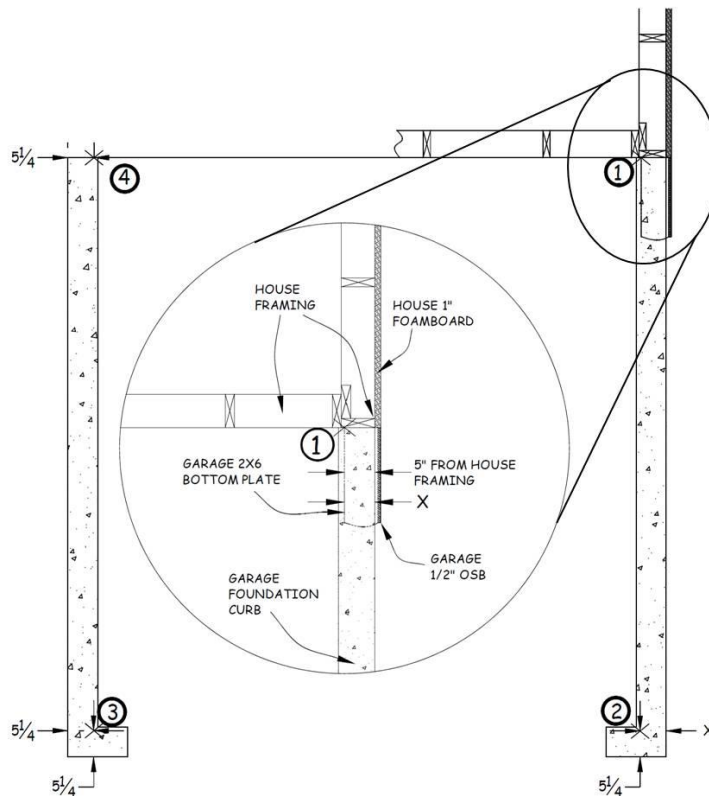

Figure 23-1. Garage Sill Plate Chalk Lines.

4. In a similar manner to that described in Section 1.1, square the foundation. Using a long steel tape, measure between the marks of opposite walls and adjust to equalize. Then, measure the diagonals between the corners and adjust wall lengths to achieve a square foundation.
5. From those final marks on each corner snap chalk lines.

23.2. MEASURING AND CUTTING WALL PLATES

1. Before cutting the wall plates, consult the Plate Layout Drawing for pre-defined plate lengths (hand-drawn on the printed plan).
2. Most upper plates will be sized to place the free ends of the plates over a window or door header.
3. Some plate lengths will be shown with a (+/-) designation. This means that a standard-length 2x4 can be used without cutting. Other pieces will be shown with an exact length. They should be cut precisely to that length.
4. The length of the last piece necessary to extend to the other end of the garage wall is typically not specified because of possible differences between the Garage Plan and actual garage size. Measure and cut these pieces to fit.

NOTE: In selecting pieces to be cut, use standard lengths of 8' to 16' wherever possible. Use treated lumber for the bottom plates.

5. Mark and drill bolt clearance holes on the treated bottom plate. Use a $\frac{3}{4}$ " or $\frac{7}{8}$ " bit to drill holes larger than the bolt diameter in order to allow correct positioning of the plates on the foundation.
6. After cutting the upper and bottom plates according to the Garage Plan, tack the plates together with 16d duplex nails and set them in location on the garage floor.

23.3. MARKING WINDOW & DOOR LOCATIONS ON EXTERIOR WALL PLATES

1. Starting at the garage zero corner (where the front wall meets the side wall), lay out the longest walls first. Stand the plates with their outside edges facing up and make layout marks on these edges. Using a tape measure attached to the plate at the zero end, mark the center-line location of all windows and doors with a short VERTICAL line overlaid with a "C" and an "L", to create a mark for center line (Ⓞ). Mark both upper and bottom plates with the window and door size shown on the layout (e.g., 3030 Window, 3068 Service Door, or 16070 Garage Door).
2. When laying out the exterior walls that intersect the longest walls, again start at the zero end but this time extend the tape measure $3\frac{1}{2}$ " beyond the end of the plate. This offset takes into account the $3\frac{1}{2}$ " width of the intersecting long wall plate wall during layout.
3. Referring to the window or door size, measure and mark the location of the King and Jack studs that support the header (see Figure 3-4.)
4. The separation between the Jack studs (the "rough opening") for all windows equals the width of the window being located. The rough opening for the service door is $2\frac{1}{2}$ " wider than the door size. The rough opening for the overhead door is 1" wider than the

door size. The first two digits in the window or service door code and the first three digits in the overhead door code are the width in feet and inches, not inches.

EXAMPLE: A 3030 window is 3'-0" wide (not 30") wide; in this example, the rough opening between the Jack studs is 3'-0" or 36". For a 3068 service door, the rough opening is 3'-0" + 2½" = 36" + 2½" = 38½". For a 16070 overhead door, the rough opening is 16'-0" + 1" = 16'-1".

5. Label the King and Jack stud locations with "K" or "J" to specify the location of the pre-built window and door components during wall assembly.
6. Occasionally, the opening in the foundation for the overhead door is 3" wider than the door width. When this situation is present, the innermost Jack stud at both sides of the opening will "overhang" the foundation. Therefore, the two innermost Jack studs must be cut long enough to reach the garage floor rather than the foundation plate. The bottom of these studs must rest on a separate bottom plate or be protected from contacting the garage floor directly in some other fashion (e.g., protective tape or a lower section of 2x4 treated lumber).
7. Label the upper plate "Header Up" to specify that the header will lie above the deck while the wall is built. It will place the header on the outside of the wall when erected.

23.4. MARKING STUDS ON EXTERIOR WALL PLATES

1. Lay out studs on the long parallel walls first. Before marking the stud locations, check opposite walls to be sure there are the same length (within ⅛"). If not, trim to equalize.
2. Starting at the zero end, hook a tape on the end of the plates and mark the location of all wall studs on 24" centers. Center the stud marking jig on these center marks, mark both edges of each stud, and place an "X" within the two stud marks. If the stud marking jig is not available, use the tape measure to mark the stud edges ¾" on either side of the center mark.

NOTE: By design, some stud locations will coincide with a window or door King stud. In these instances, leave the "K" designation already marked on the plates. If the "K" location is not on-center, it may need to be moved (see the Site Leader or Construction Supervisor).

3. Wherever 24" centers fall within a window, mark a "SX" on the bottom plate to represent a short stud under the window. Wherever a stud falls within either a window or a door opening, mark a "SX" on the upper plate to represent a short stud between the header and the upper plate.
4. At each end of the long walls, lay out an L-corner with two 2x4 studs made up of the normal 2x4 end stud plus an extra 2x4 stud perpendicular to the end stud on the interior side of the wall (see Figure 23-1). Mark the "L" as "Corner Down" to specify that the extra 2x4 will lay face down on the deck as the wall is being built. This will place the existing 2x4 stud facing the end of the adjoining short wall forming an inside corner.

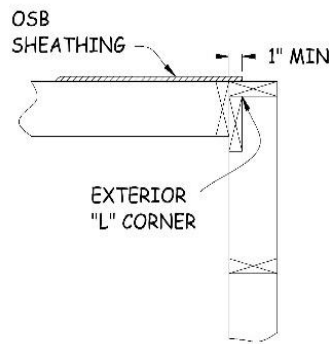

Figure 23-1. Exterior L-Corner.

5. On the short wall, add an additional stud either at the end of the wall or inside the wall unless a window can be moved slightly to place the King stud 48" from the outside corner of the house.
6. After marking the long walls, locate and mark the studs on the short walls. Starting at the zero end, extend the tape measure 3½" beyond the end of the plates and mark the stud locations on 24" centers. Place "X's" and "SX's" as appropriate.

23.5. ERECTING GARAGE WALLS

23.5.1. Preparation

1. Before the walls are erected, establish the length of the wall King studs.
 - a. For the detached garage, use standard nominal 9' 2x4 garage studs (104⁵/₈".
 - b. For the attached garage, measure from the garage foundation wall to the top of the upper plate of the house wall. Do this at the front and back garage foundation walls. If the two measurements are not the same, split the difference. Subtract 4½" (1½" bottom plate, 1½" upper plate and 1½" for the top plate) and that will be the 2x4 stud length. The studs may need to be cut to proper length from 2x4 lumber.

NOTE: These measurements may be very close to 104⁵/₈". If so, consider using the nominal 9' garage studs instead of cutting other lumber (see Construction Supervisor for directions).

2. Measure and record the height of the wall foundation at both the service door and overhead door locations (typically 4").

3. After establishing the stud lengths, prebuild the window and door components. See Chapter 4 for general guidance for the window and service door components. See the overhead door specifications for the overhead door component. In all cases, note that garage components are built with 2x4 rather than 2x6 lumber.

NOTE: With the exception noted in Section 23.3.6 above, the Jack and King studs for all components will rest on the garage foundation wall. However, the door units will rest on the garage floor.

23.5.2. Construct Service Door Component

1. Cut two King studs to the length determined in Section 23.5.1.1 above. Cut two Jack studs from treated lumber to 82" (these studs will extend past the foundation wall to the garage floor).
2. Nail each Jack stud to a King stud, with the bottoms flush and the crowns opposite, using pairs of 3¼" collated nails no more than 12" apart.
3. Cut two 2x10 header pieces and one 2x4 header piece 3" longer than the rough opening of the door (e.g., 41½" for a 3068 door).
4. Nail the 2x10s together with two rows of 3¼" collated nails. Tack the 2x4 to one long edge of the 2x10 pair, taking care to keep three edges flush.
5. Working on a flat surface, place the header between the King studs, flat surface up, and the 2x4 resting on the top of the Jack studs.
6. Square the 2x4 to the King stud, flush with the top of the Jack studs, and nail with two 3¼" collated nails.

NOTE: It is critical that the header be flush with the top of the Jack stud to properly transfer roof load to the foundation.

7. Keeping the surfaces of the header and King studs flush, nail the King studs to the header with three 3¼" collated nails into the ends of each 2x10. Finish nailing the 2x4 header piece into the underside of the 2x10's with 3¼" collated nails.
8. Cut a piece of ½" OSB the size of the header and nail to one side. Label the opposite side of the header "Inside".
9. Cut a 1x4 "filler" piece 38½" long to fit between the Jack studs and nail it to the underside of the header. This helps to limit the gap between the header and the top of the door. (See Figure 4-1.)

23.5.3. Construct Window Components

1. For each window, cut two King studs to the length determined in Section 23.5.1.1 above. This will locate the top of the header of both the window and door at the same elevation in the wall.
2. Cut a 2x4 sill piece the width of each window (e.g., 36” for a 36”-wide 30XX window).
3. Construct double 2x10, 2x4 headers similar to that for the door, but 3” wider than the width of the window (e.g., 39” wide for a 36”-wide 30XX window).
4. On each Jack stud, measure down from the top and mark the stud with the height of the window (e.g., 24” for a 3020 window).
5. Nail the Jack studs to the King studs with pairs of 3¼” collated nails, no more than 12” apart.
6. Place the header tight to the top of the Jack studs, flush the appropriate surfaces, and nail through the King stud into the ends of the header pieces with 3¼” collated nails.
7. Place the sill piece between the Jack studs at the mark made in Step 4 above and square to the frame surface. Drive two 6” Timberlok® screws through the King/Jack pair into the sill.
8. As with the door header in Step 6 above, cut and attach a piece of OSB to one side of the header. Label the opposite side “Inside”.

23.5.4. Construct Overhead Door Component

1. Refer to the door specifications to determine the width and height of the rough opening.
2. Cut two King studs to the length determined in Step 23.5.1.1 above.
3. Measure the width of the opening in the foundation wall.
 - a. If equal to the width of the rough opening, cut four Jack studs the height of the door header, less the height of the bottom plate above the floor (e.g., 7’0” – [4” + 1½”] = 6’6½”). Using 3¼” collated nails throughout, nail the King studs to double Jack studs, and nail the assemblies between the upper and bottom plates using the appropriate marks on the plates (see Section 23.3 above).
 - b. If not equal to the width of the rough opening, cut only two Jack studs to the designated length, nail them to the King studs, and nail the assemblies between the upper and bottom plates as in Step 3.a above. However, since the two inner stud locations will be empty at this point it will be necessary to cut and

install those studs after the wall is up and the header has been installed (see Section 23.5.5.13 below).

4. Cut one (or as appropriate, two) header pieces to a length equal to the distance between the two King studs. Set aside for wall construction.

23.5.5. Assemble and Erect the Walls

1. Remove the temporary nails connecting the upper and bottom plates of the wall section and separate on the deck. Be sure the words “Upper” and “Bottom” remain in the same orientation.
2. Select studs for framing walls by sighting along the edge of each stud to determine in which direction the stud is crowned; mark with an arrow pointing to the high side. Place studs with “crown up”.
3. Assemble each exterior wall on the garage floor and then erect in one entire section. Assemble the two full-length exterior walls first. Assemble and erect the gable-end wall after the two longer walls are up.
4. Place the separate window and service door components in place between the upper and bottom plates with the “Header Up” orientation (this places the “smooth” surface of the header on the outside of the wall).
5. After assembling the other overhead door components, do not install the header at this point. If the header piece is installed while the wall is on the ground, the wall will be too top heavy to lift safely.
6. Nail all wall sections together with 3¼” collated nails using two nails through the plates into the ends of each stud. Always make sure that the edges of the studs are flush with the edges of the plates.
7. Place foam sill seal on the foundation wall slightly back from the chalk line. Stand the wall section up, making sure the bolts emerge through each pre-drilled hole. Align the wall so it is flush with the chalk line, then add the washer and nut to each bolt and tighten.
8. In an attached garage, one end of both the front and back walls connects to the house wall and can be plumbed and secured to the house. The other end of each wall needs to be supported using a long 2x4 nailed to the wall near the top and to a 2x4 stake (minimum length of 2’) pounded into the ground. For a detached garage, install 2x4 braces at all corners. Make sure the front and back walls lean out slightly when they are braced so they will not interfere with the installation of the gable end wall.
9. The gable end wall panel is constructed, erected and braced in the same manner as the wall panels above. Fasten wall panels to each other by flushing the corners and

nailing with 3¼” collated nails the adjoining end studs every 12” from bottom to upper plate.

10. At each inside wall corner, nail a long 2x4 brace into the upper plate and run it diagonally down to the bottom plate. Plumb the wall corner. Nail the brace into the bottom plate and into two of the wall studs with one 16d duplex nail at each point.
11. After all the walls are up and braced, install the overhead door header cut in Section 23.5.4.4. Lift one header piece up onto the Jack studs, flush with the exterior of the framing. Nail into place with four 3¼” collated nails through the King studs into the header piece. Lift the second header piece into place, holding it tight against the first header piece and nail through the King stud using 3¼” collated nails.
12. Nail the two headers together with 3¼” collated nails - three nails on 18” centers on both sides of the beam, staggering the nail lines on opposite sides of the beam.
13. If double Jack studs were not installed in Section 23.5.4.3, a second Jack stud now needs to be installed on each side of the door opening. Cut two pieces of treated 2x4, each about 2’-3’ long. Cut one end of each piece at an angle to match the slope of the garage floor. Place each piece on the floor and nail to the first Jack stud with pairs of 3¼” collated nails. Measure from the top of the cut piece to the underside of the header. Cut a piece of untreated 2x4 that length and nail to the first Jack stud to complete the installation. Ensure that the untreated piece is tight to both the header and the treated piece to properly carry the load of the header

23.6. STRAIGHTENING GARAGE WALLS

23.6.1. Attach String Line

1. To straighten the exterior walls, stretch a VERY taut string line from one inside corner to an adjacent inside corner. The wall is adjusted to the string line every 8’–10’ and braced to hold.
2. For each exterior wall corner, cut a scrap length of 2x4 about 10-12” long.
3. Drive a 16d nail into the approximate center of this 2x4, leaving the nail about ½” above the 2x4 (this is left to wrap the string around), and approx. 1” sticking out the bottom. Be sure the nail is straight, since the nail above the 2x4 represents the inside of the corner.
4. At the exterior wall “inside” corner, place the 2x4 on top of the 2x6 upper plates at roughly a 45° angle so that the point end of the 16d nail rests tight against the “inside” upper plates of both walls (nail resting tightly against the inside of the corner). See Figure 5-2.

5. Nail the 2x4 to the upper plate with two 16d or duplex nails on each end of the 2x4. Nail securely as there will be a lot of string tension on these.
6. In the first corner, attach the string line on any nail other than the centered nail (feel free to add additional “tie off” nails as needed)
7. Wrap the string the exterior of the centered nail, aligned with the inside edge of the upper plates on each wall
8. Continue around the exterior walls, repeating Steps 4 thru 6 at each corner, until back at the starting corner. Make sure the string is not obstructed between corners and is VERY taut.
9. At each corner, verify that the string is aligned with the “inside” of the upper plates and adjust as needed.

23.6.2. Straighten the Walls

1. Start approximately 5’-7’ from the corner.
2. Place one end of a 6’ level against the top plate and the other against a nearby stud - not the stud immediately below. (This “two-point contact avoids problems with a bowed or twisted stud.)
3. Slide the level up the wall until it reaches the string. If the top of the level touches the string, adjust the bracing to move the wall in until the inner edge of the level lines up with the string. If the level misses the string, move the wall outward until the inside edge lines up with the string. The wall is now straight in that section. Then brace appropriately.
4. Move approximately to the mid-point of the wall and repeat Steps 2 and 3.
5. Repeat Steps 1 thru 4 for the remaining exterior walls. After bracing for all exterior walls is completed, recheck the alignment (using the string line) and remove string and blocks.

23.7. INSTALLING TOP PLATES AND SHEATHING WALLS

1. Walls must be tied together by nailing overlapping top plates to the tops of all walls. Top plates at the intersection of interior and exterior walls are done first.
2. The top plate on all bearing walls must be lapped a minimum of 4’ on each side of the wall plate joint, and at each corner.
3. Top plates of the garage walls that intersect the house walls must extend into the houses exterior top plates by 2” and must be at least 16" long.

4. When nailing top plates, use two 16d nails across 2x4 plates. Nail at each intersection of top plates and nail at each stud location.
5. Starting at the zero corner, place a sheet of 4'x8'x $\frac{1}{2}$ " OSB on each end of a wall section, flush with bottom plate and overlapping $\frac{3}{4}$ " onto the stud 4' from the corner. Secure it to the studs with 8d or 2 $\frac{3}{8}$ " collated nails into each stud and the top and bottom plate with a 6" spacing.

NOTE: The OSB is secured with the nails spaced 6" apart, rather than the 3" spacing used when securing OSB to the house framing, because the garage is fully sheathed with OSB.

6. Continue sheathing across the wall, holding the OSB flush with the bottom plate and tight against the previous sheet. Secure it to the studs with 8d or 2 $\frac{3}{8}$ " collated nails into each stud and the top and bottom plate with a 3" spacing.