

## Chapter 9. Windows and Exterior Doors

### 9.1 INSTALLING WINDOWS

### 9.2 INSTALLING EXTERIOR HOUSE DOORS

### 9.3 INSTALLING SHED DOOR

### 9.4 INSTALLING EGRESS COMPONENTS

#### Tools needed by volunteers:

Hammer  
Nail apron  
Tape measure  
Square  
Utility knife

#### Materials needed:

Caulk  
Shims  
Weathermate™ Straight Flashing tape  
Weathermate™ Construction tape  
3” Drywall screws  
16d Galvanized casing nails  
8d Galvanized casing nails  
2½” Siding nails  
Sill pans

#### Tools and equipment needed:

Generator  
Extension cords  
Chop saw  
Caulk gun  
Paslode nailer  
6’ level  
Ladders

#### Personal Protection Equipment:

Safety glasses (required)

**Safety First! Review the Safety Checklist before performing tasks in this chapter.**

## 9.1. INSTALLING WINDOWS

### 9.1.1. Window and Rough Opening Preparation

1. Unpack the windows and check for proper size and damage. Lattice windows are always installed in the front of the house. For each opening, verify the size and type – double-hung, sliding, grids – to be installed. Measure the rough opening dimensions and check for any obstructions. If any dimensions exceed the specifications by more than  $\frac{5}{8}$ ", consider feasible corrections. However, any changes must maintain adequate nailing surface and keep the window top consistent with other windows for proper siding look.
2. Check the sill for level and cut shims to length so they fit completely inside the sill pan.

**NOTE:** Shims must be at least  $\frac{1}{8}$ " thick in order to provide drainage clearance between the bottom of the window and the sill pan and to better center the window top to bottom.

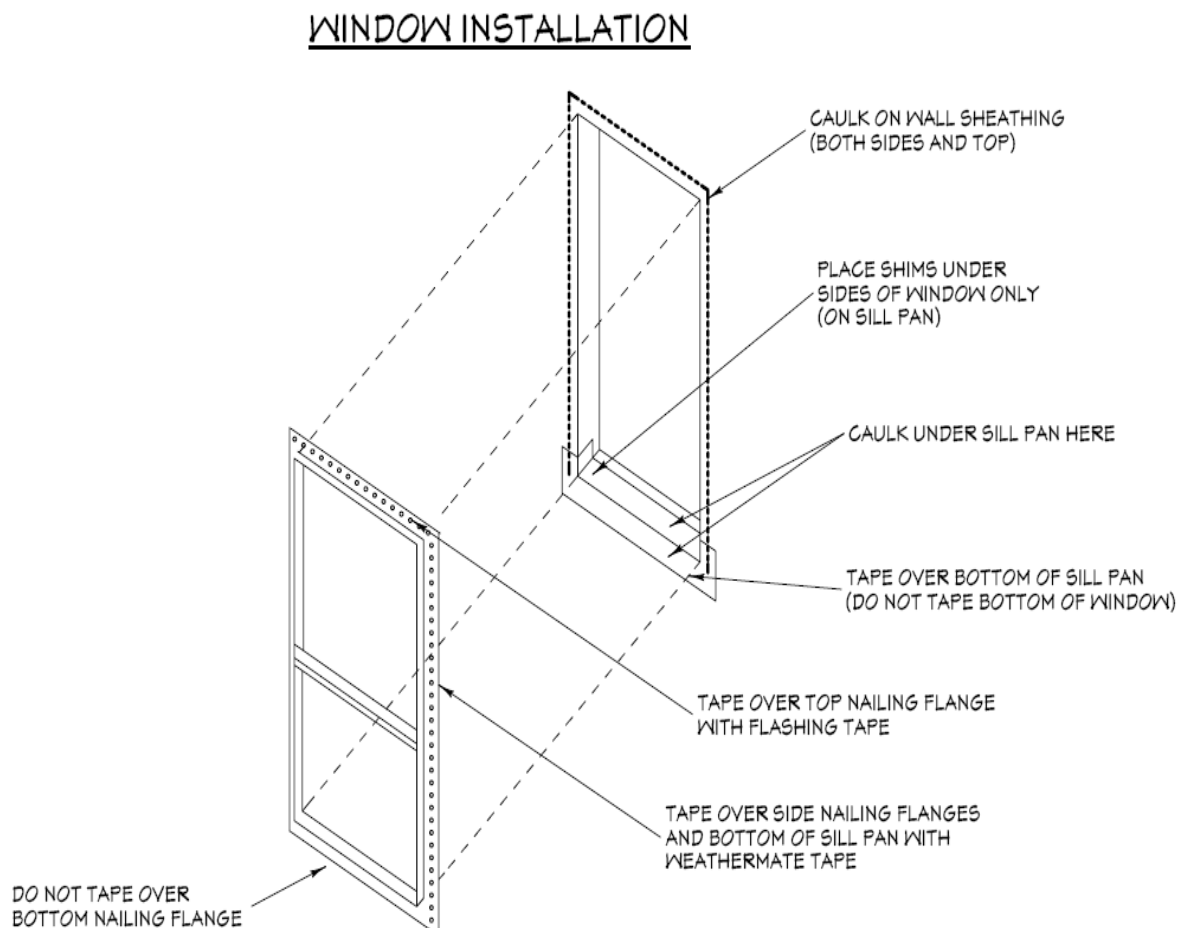

**Figure 9-1. Window Installation**

3. Run a continuous bead of caulk on the sill and 3” up the sides. Apply the caulk ½” from the exterior edge of the sill framing (not the foamboard).
4. Run a continuous bead of caulk on the exterior surface of the foamboard under the window and extending roughly 6” up both sides of the rough opening. Apply the caulk ¼” or less from the edge of the opening.
5. Install one half of a sill pan on the sill of the window opening. Be sure to seat the sill pan completely flat on the sill. Run a short bead of caulk along the center edge of the first half and then install the second half on top. Press both pieces tight to the sill.
6. Run a continuous bead of caulk on the exterior surface of the foamboard up both sides and over the top of the rough opening. Apply the caulk within ¼” of the edge of the opening.
7. Place a shim (cut to length in Step 2) within the sill pan at each end (directly under the end frame) and in the middle for windows greater than 36” wide.

#### **9.1.2. Position and Temporarily Secure Window in Opening**

1. Locate the top of the window by checking the labels, or by locating any weep holes (weep holes go to the bottom). Place window unit in the rough opening, center it left to right and check the gap at the top and bottom to make sure the window is centered vertically.

**CAUTION:** Be sure someone continues to support the window from the outside until it is secured with nails.

2. Open the window enough to place the level on the bottom frame (not on the bottom sash) and level the bottom of the window, shimming as necessary.
3. Using 2½” siding nails, nail the bottom hole in each of the side flanges of the window.
4. Using 2½” siding nails, TACK nails in the center of the leftmost and rightmost slots in the top flange of the window.
5. Raise the bottom sash just enough to create a small reveal with the bottom frame. Check to see if the reveal is uniform. If it is, this indicates the window is square. If it is not, rack the top of the window frame left or right until the reveal is uniform and the window is square. To adjust the reveal, pry the top of the frame in the direction of the wider reveal.

**NOTE:** Before attempting to rack the window, place temporary shims in the lower corner opposite to where the pry bar will be inserted. Be sure to remove these shims when the window is fully nailed.

6. Finish securing the nails in the leftmost and rightmost slots in the top flange of the window installed in Step [4](#).

### **9.1.3. Permanently Secure Window**

1. Using a level held against the INSIDE window frame, verify that all four sides are straight, and make a mark on the foamboard near the center hole on each side; nail, with 2½” siding nails, snugly through the center hole of each flange to hold them straight. Use the mark on the sides to verify that the frame has not moved when nailing. Do a final re-check of the reveal and window operation before nailing the rest of the slots.

**NOTE:** Make sure to pound the nails in straight. If they are even slightly angled, they will push the frame of the window in toward the windowpane. When this happens, the window becomes very hard to open and close because the window frame is now too narrow. To protect the window frame when nailing, hold a shim, putty knife, or flat wrecking/pry bar flat against the frame. If the nail is missed, the hammer will hit the protective device and not the frame.

2. Tape the bottom of the sill pan to the foamboard with Weathermate™ Construction tape. Do NOT tape the bottom flange of the window to the sill pan. Next, tape the side flanges with Weathermate™ Construction tape, being sure to overlap the bottom tape. Lastly, apply Weathermate™ Straight Flashing tape to the top, being sure to overlap both side tapes. This order establishes a “shingle style” drainage plane.

## **9.2. *INSTALLING EXTERIOR HOUSE DOORS***

### **9.2.1. Door and Rough Opening Preparation**

1. Before removing packaging or shipping parts, inspect the door and frame. If there is any damage, notify the Site Leader or Construction Supervisor.
2. Remove bags of door accessory parts from the door frame and attach to one of the king studs for the door.
3. Verify correct door and size. Verify proper door swing according to the House Plan.
4. Using a ⅛” drill bit, pre-drill the brickmold where 16d galvanized casing nails will be placed (five on each side and three on top). Hold the holes near the upper mitered corners 3” away from the corner. Angle the holes slightly away from the jambs to ensure that the casing nails will hit the Jack stud.
5. If house wrap extends through the doorway, fold it down over the threshold area and staple it to the deck in the doorway.

6. Verify that Weathermate™ Straight Flashing tape has been installed in the rough opening threshold area (covering corner of decking and foamboard and 2” up each side of Jack studs). Install “Threshold Seal” tape snug to corners (do not run up the Jack studs).
7. The following Steps 8 and 9 are designed to reduce the difference between the width of the door frame and the width of the rough opening at the hinge locations to  $\frac{3}{8}$ ” or less. Doing so helps to
  - Center the door in the rough opening;
  - Avoid trying to install spacers and/or thick shims once the door is in place; and,
  - Equalize the overlap of the interior trim.
8. Mark the location of the hinges on the hinge side Jack stud. Using a 6’ level, check if the Jack stud is plumb.
  - a. If PLUMB, measure the width of the door frame at the head jamb and the width of the rough opening at top and bottom hinge locations. If the difference at both locations is less than  $\frac{5}{8}$ ” proceed to Step 9 below. Otherwise,
    - i. Nail (with 1¼” white trim nails) an equal number of ¼” spacers to the hinge side Jack stud at the top and bottom hinge locations until the difference is less than  $\frac{5}{8}$ ” at both locations.
    - ii. Place the level against the top and bottom spacers/shims and install spacers and/or shims at the middle hinge area until flush with the level.
    - iii. Proceed to Step 9 below.
  - b. If NOT PLUMB, measure the width of the door frame at the head jamb and the width of the rough opening at the top and bottom hinge locations.
    - i. If the difference at either location is more than  $\frac{5}{8}$ ”, nail (with 1 ¼” white trim nails) the appropriate number of ¼” spacers and/or shims to the top and/or bottom hinge locations of the hinge side Jack stud until the width of the door frame is less than  $\frac{5}{8}$ ” at both locations.
    - ii. Place the 6’ level against the spacers. If not plumb, shim top or bottom hinge areas until it is plumb and then install spacers and/or shims at the middle hinge area until flush with the level.
9. Add one or two layers of ¼” spacers and/or shims to the strike side stud at the top and bottom hinge locations until the differences in opening width at the top and bottom hinge locations is less than  $\frac{3}{8}$ ”. Place the 6’ level against the spacers and then install spacers and/or shims at the middle hinge area until flush with the level.

### 9.2.2. Position and Temporarily Secure Door in Opening

1. Set door into the rough opening, tight to the foamboard and hinge side Jack stud.
2. Temporarily secure the door in the rough opening by installing shims at the very top of the strike jamb (even with the head jamb) AND at the very bottom of the strike jamb (even with the threshold). At both locations, wedge (do NOT nail) these shims in **TIGHTLY** (they can be adjusted later).

**NOTE:** This process is designed to apply horizontal pressure to hold the hinge jamb tight against the hinge side Jack stud. The top of the door may rub on the strike jamb at this stage, but this is normal and will be corrected later.

3. Check the reveal between the top of the door and the head jamb at the left and right corners of the door. If necessary, shim at either the top or the bottom of either side jamb until these reveals are equal.
4. Re-check that the hinge side is still plumb (set level on hinges or hinge plates).
5. Tack four 16d galvanized finish nails into pre-drilled holes in brickmold, two on each side near top and bottom to hold door tight to foamboard.

### 9.2.3. Permanently Secure Door

1. With the door held tight to the foamboard and the hinge side Jack stud, secure the hinge side jamb with 3” drywall screws behind the weatherstripping at the top, middle and bottom hinges.
2. Check that the hinge side of the door is still plumb. Adjust shims as needed.
3. Replace two short screws from the top hinge (the two screws closest to the weatherstripping) with #10 3” construction screws (brass-colored). Make sure the screws are driven into the Jack stud. These screws ensure the door will not sag over time.

**NOTE:** The tightness of the 3” brass screws in the top hinge can affect the reveals at either end of the head jamb. Tighten or loosen the screws as needed to adjust the reveals.

4. Recheck that the reveals remain equal at both ends of the head jamb. Adjust the strike side up or down as needed.
5. Check complete door operation and verify that contact between the door and the weatherstripping is consistent (no gaps or light visible) along the head jamb and the strike jamb. It may be necessary to adjust the strike side jamb and brickmold slightly away from the foamboard to ensure proper contact with the weatherstripping

(a maximum of  $\frac{1}{8}$ " gap and shimmed behind brickmold to hold in place). Confirm that the latch and strike are aligned.

6. Check the reveal on the top and the bottom of the hinge jamb. If necessary, adjust the shims against the head jamb until the top hinge jamb reveal matches the reveal just below the top hinge. If necessary, adjust and shim the bottom of the hinge jamb to match the reveal at the top, shim as needed, and secure with a 3" drywall screw behind the weatherstripping.

**NOTE:** Adjusting the reveal at the top of the hinge jamb will affect the reveal at the top of the strike jamb. Check to be sure the reveal at the top of the strike jamb is  $\frac{1}{8}$ " or greater. If not, it may be necessary to "split the difference".

7. Check the reveal at the top and the bottom of the strike jamb. If necessary, adjust the shims at the bottom of the strike jamb until there is a consistent reveal at both locations.
8. While keeping consistent reveals top to bottom, install all remaining shims (using 3" drywall screws behind the weatherstripping) in the following strike side locations: across from the top and bottom hinges; and, above and below the dead bolt location.
9. Install shims in the center of the head jamb, adjusting for a consistent reveal across the jamb. Secure the shims with a 3" drywall screw behind the weatherstripping.
10. Recheck the complete door operation, ensuring that contact with the weatherstripping is uniform (no gaps or light visible) along the head jamb and the strike jamb, and that all reveals are consistent. Adjust as needed.
11. To obtain consistent reveals along both side jambs, install additional shims on the hinge side about halfway between hinges and similarly on the strike side. This should result in five sets of shims per side (plus one extra set above the deadbolt). Secure the jambs with 3" drywall screws behind the weatherstripping.
12. Finish securing the door on all three jambs at each shim location by nailing a 16d galvanized casing nail through the jambs along the exterior side of each jamb (between the doorstop and brickmold). Make sure all nails hit a Jack stud or the header.
13. Nail the brickmold using 16d galvanized casing nails in the thirteen pre-drilled holes. Make sure all nails hit a Jack stud or the header.
14. Conduct a final verification of the complete door operation, ensuring there is uniform contact with the weatherstripping and that all reveals are consistent. Adjust as needed.
15. Set and caulk all nails.

### 9.2.4. Installing Hardware and Window Trim Caps

1. Install lockset and deadbolt. Use the specially provided security deadbolt strike plates rather than the one provided with the lockset.

**NOTE:** Make sure the deadbolt is installed so that the top of the lever turns in the direction of the bolt travel. If it does not, remove the deadbolt from the door, rotate it 180° and reinstall.

2. Make sure both the lockset and deadbolt are installed so the key direction (notches up) is the same. If necessary, the lockset can be changed to place the notches up, as follows. Unlock the installed lock. Insert the key **half-way** (do not insert completely). Push in the retainer pin (H) on the neck of the knob and pull the knob just past the pin. Continue holding the knob and use the half-way inserted key to rotate the cylinder (J) to the correct orientation. Push in the retainer pin and push the knob back into place. **Do NOT pull the knob and cylinder off the shaft while doing this**

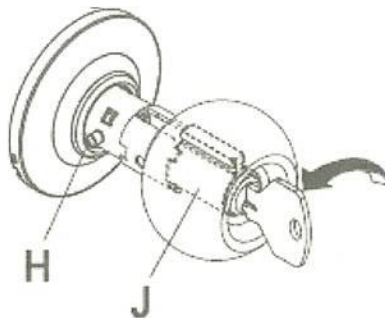

**Figure 9-2. Door Lockset.**

3. Verify lockset and deadbolt operation. Adjust as needed for easy operation (door closes snugly to weatherstripping and latches with little effort, the deadbolt easily engages and disengages when door is closed, and the deadbolt moves in the same direction as the top of the lever).
4. For doors with a window, install the white plastic trim caps, being careful to install them in the correct orientation. Install by hand until almost flush, or as far as possible, then use a wood shim and hammer to tap until the cover is flush with the trim surface.

### 9.2.5. Weatherproof/Air Seal Doors

1. If threshold covers are not available, temporarily protect the **wood** (not the aluminum) portion of the threshold with 2" blue painter's tape (two or three layers).
2. Apply Weathermate™ Straight Flashing tape to the foamboard and the side of the brickmold making sure the tape does not extend more than 3/4" onto the brickmold



(so that it will be completely covered by the siding J-channel). To facilitate attaching this tape to the foamboard and brickmold, use a 2x4 (for 4" wide tape) or 2x6 (for 6" wide tape) as a template to mark a line on the wall 3½" or 5½" from the brickmold. While gradually peeling back the release paper, align the edge of the tape to the line, and stick the edge to the foamboard. While progressing down the wall, use a speed square or wide putty knife to evenly press the tape to the foamboard, pushing the tape into the corner between the foamboard and the brickmold. Finally, press the edge of the tape to the brickmold, making sure it is tightly attached all over and is tucked tightly into the corner (radius smaller than the J-corner radius). The result will be about ½" of tape stuck to the brickmold.

3. Apply the tape to the door sides first, then the top (shingle style). For the sides, tape can be applied in a single piece or multiple pieces (easier) not less than 20" in length and overlapping about 2" starting from the bottom (shingle style). The top piece of tape must be a single piece extending above and past the outside edges of the side tapes.
4. Install bottom "Corner Seal Pads".

### 9.3. **INSTALLING SHED DOOR**

1. Install the shed door following the standard installation procedure described in Section 9.2 above with the addition of the following two steps.
2. Create (or use pre-made, if available) and install an aluminum drip cap over the top of the door casing. Cut the flashing 1" longer than the top brickmold. Install it with ½" extension beyond each end of the brickmold. See Figure 9-3.

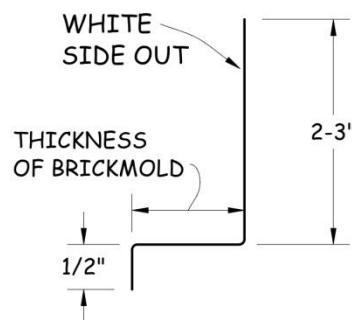

**Figure 9-3. Shed Door Drip Cap.**

3. Install a triangular piece of roofing felt or house wrap on the gable shingled over the flange of the drip cap to keep water from getting into the OSB seam and behind the door from the top. Do the same on the back gable end to cover the gable and wall OSB seam.

**NOTE:** Do NOT apply Weathermate™ Flashing tape to the brickmold (it won't stick to the OSB surface) or the deck under the threshold as it is not required here. Do NOT apply any threshold sealing tape to the shed deck rough opening.

## **9.4. INSTALLING EGRESS COMPONENTS**

### **9.4.1. Install Windows and Screens**

1. Clean debris from tracks.
2. Install window sashes with label right-side up.
3. Install the screen.

### **9.4.2. Finish Drain Tile Installation**

1. Locate the drain tile protruding through the stone at the bottom of the egress well.
2. The top of the tile should be 2"-3" below the bottom of the window sill. If it extends higher than this, use a utility knife to cut off the top of the tile to the desired height.
3. Install the end cap on the drain tile.
4. Cover the end cap with stone flush with the bottom of the window sill in order to hide the drain tile.

### **9.4.3. Install Egress Ladders**

1. Hang the ladder on the rim of the egress well wall opposite and approximately centered on the window.
2. Drill through the bottom two holes in the ladder into the egress well wall with a 3/16" drill bit.
3. Install a 1 3/4" Tapcon screw into each hole.

### **9.4.4. Install Egress Cover**

1. Simply set the cover in place - no fasteners are required.
2. Place a sheet of 3/4" OSB or two sheets of 1/2" OSB over the egress cover until the home exterior is finished. This gives strength to the cover for standing and/or ladders and keeps dirt and straw from going into the egress well during landscaping.