

10. Vents, Baffle Guard and Blocking

10.1 INSTALLING BATH FAN AND END CAP

10.2 INSTALLING RANGE PLENUM AND END CAP

10.3 INSTALLING PROPER VENTS

10.4 INSTALLING WIND WASHING BAFFLE GUARD

10.5 INSTALLING BLOCKING

Tools needed by volunteers:

Hammer
Nail apron
Tape measure
Square
Utility knife
Pencil

Materials needed:

Scrap 2x lumber
Scrap OSB
Proper vents
1" Foamboard
Weathermate™ Construction tape
3" Weathermate™ Straight Flashing tape
16d Nails
3" Siding nails
1½" Drywall screws
3" Drywall screws
Range plenum

Tools and equipment needed:

Generator
Extension cords
Circular saw
Chop saw
Stapler
Paslode nailers
Torpedo level
Stepladders

Personal Protection Equipment:

Safety glasses (required)

Safety First! Review the Safety Checklist before performing tasks in this chapter.

10.1. INSTALLING BATH FAN AND END CAP

1. Check for the location of the bath fan per plan. It must be installed per this plan. These bath fans are activated by a motion detector and will not operate as designed if not installed per plan.
2. First install the fan's end cap. The end cap needs to be a straight run from the fan. It is usually installed above the top cord and next to a vertical 2x4 of the gable truss. This provides framing material to nail the end cap to the house.
3. After establishing the location of the end cap, cut the opening for the short vent pipe on the end cap that goes through the wall. Take care to cut this only big enough for the vent pipe to slide through
4. Slide the pipe through the hole, level the end cap and nail into framing with 3" siding nails.
5. Check that the back draft flap on the bath fan is working correctly by removing the factory-applied shipping tape securing the flap to the fan.
6. Frame out an opening with 2x4's where the fan will go in the bottom cords of the trusses.
7. Secure the fan to the framing with 1⁵/₈" drywall screws. Make sure the fan's exhaust port is pointing toward the intended gable end. Set the fan body tight to the truss that the exhaust port points away from, to allow as much space as possible for the rigid duct to angle up and over the exhaust side truss's bottom chord.

10.2. INSTALLING RANGE PLENUM AND END CAP

10.2.1. Preparing Plenum Location

1. After sheathing the exterior of the stud bay at the stove location, install the range hood plenum. Measure from the floor up 71¹/₂" and mark on both studs. These marks represent the top of the plenum.
2. Cut a 2x4 plenum support block to fit between the two studs. Install the block flat with the bottom side at the 71¹/₂" marks and the edge flush with the inside edge of the studs.
3. Note the marking on the floor indicating where the center of the stove will be. Measure from the closest end wall to that center mark or, with a 6' level, plumb up from the floor mark. Mark that measurement on the 2x4 installed in Step 2.

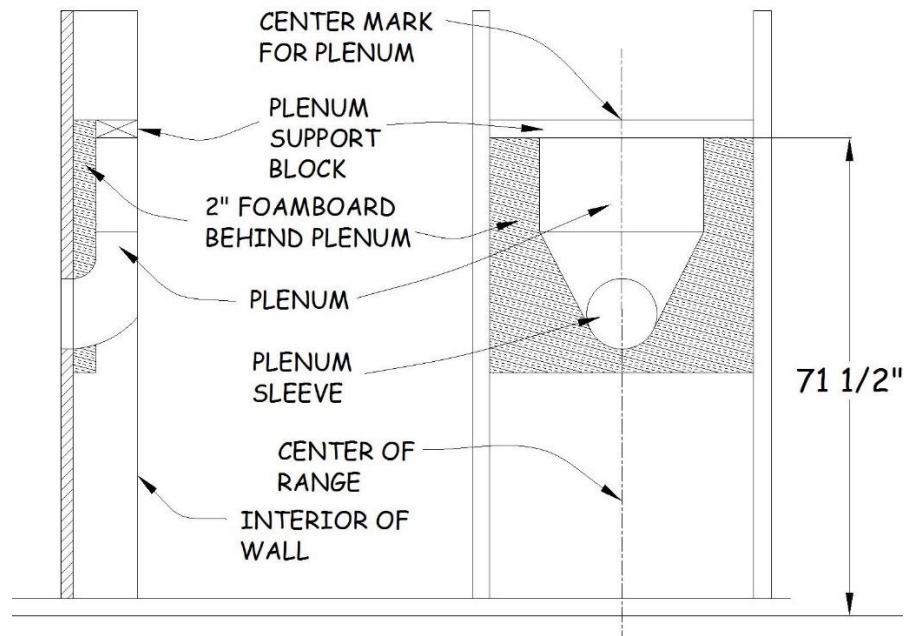

Figure 10-1. Range Plenum Location.

10.2.2. Preparing for Installation of the Plenum and End Cap

1. At the top of the plenum, measure and mark the center. Line up the plenum center mark with the 2x4 center mark.
2. Slide the plenum toward the exterior until the 6" diameter sleeve touches the wall sheathing.
3. Trace around the exterior of the plenum sleeve marking a 6" circle on the interior side of the sheathing. Increase the diameter of this circle by 1/2"-1" in order to allow room for installation of spray foam to seal the penetration in Section 10.2.3.6 below.
4. Cut out the larger circle in the sheathing.

10.2.3. Plenum and End Cap Installation

1. Cut 2" of foamboard to match the width of the space between the studs and the length from the TOP of the 2x4 supporting the plenum to the bottom of the plenum. Install this foamboard between the 2x4 and the wall sheathing, flush with top of the 2x4.
2. From outside the house sheathing, extend the circle cut out in Section 10.2.2.4 above completely through the 2" of foamboard just installed in the previous step.

3. Remove the 2" of foamboard from the stud bay. Draw a horizontal line through the diameter of the opening in the foamboard and cut the 2" of foamboard along that line. Place the foamboard pieces on the ground near the work area.
4. Align the plenum and 2x4 center marks. While holding the plenum flush to the interior side of the wall framing and the 6" plenum sleeve protruding into the wall, secure the plenum to the 2x4 using four 1 $\frac{5}{8}$ " drywall screws through the plenum flanges.

NOTE: Make sure the top end of the plenum is flush with the interior side of the wall framing.

5. Using 16d duplex nails, temporarily brace the bottom end of the plenum so it remains flush with the interior wall by nailing a piece of 2x4 across the two studs on either side of the plenum.
6. Measure from the outside of the exterior sheathing to the vertical face of the plenum, subtract 1", and cut the vent cap sleeve to that length.
7. Put a thick bead of caulk around the inner diameter of the vent cap sleeve. From outside the house, slide the vent cap sleeve through the hole in the sheathing and around the plenum sleeve (there should be a minimum of 1 $\frac{1}{2}$ " overlap). Make sure the vent cap is tight to the exterior sheathing AND the bottom end of the plenum is flush with the interior side of the wall framing.

NOTE: The entire plenum needs to be flush or slightly shy of the interior side of the wall framing so it does not cause an issue with wall rock installation

8. With a torpedo or other short level, ensure the top of the vent cap is level. Secure the vent cap in place by taping (shingle style) the flanges with Weathermate™ Straight Flashing tape.
9. From the inside, caulk or spray foam, as required, around the penetration through the exterior sheathing to completely seal the opening.
10. Seal the connection between the plenum sleeve and the vent cap sleeve using Weathermate™ Straight Flashing tape.

NOTE: The connection needs to be completely sealed in order to prevent ANY warm exhaust air from getting into the wall cavity.

11. Re-install the 2" of foamboard removed in Step 3 above, making sure they are positioned as specified in Step 1.

10.3. INSTALLING PROPER VENTS

1. Proper vents are placed between every truss on each side of the house. The proper vents have a flap on the bottom that is secured to the wall foamboard to prevent windwashing of the insulation.
2. To install, place the vent between the roof trusses and slide the vent toward the outside until the vent touches the foamboard. Make sure that the bottom of the proper vent is positioned 3” above the top of the top plate (this is equivalent to the thickness of two 2x4’s). Doing this will allow proper air flow above the vent and will prevent windwashing.

NOTE: It is recommended to do this install from a plank set up on brown, heavy duty non-folding sawhorses, with a short stepladder to get up to and down from the plank.

3. Staple (four per side) the sides of the vent to the trusses and tape the flap to the foamboard. Tape any openings, using Weathermate™ Construction tape, as shown in Figure 10-2.



Figure 10-2. Proper Vent Installation.

10.4. INSTALLING WIND WASHING BAFFLE GUARD

1. A wind washing baffle needs to be installed on houses where the porch roof is on the eave side of the house. This prevents wind from entering through the porch soffit and blowing the attic insulation away from the exterior walls.
2. Install sheets of 1” foamboard between the trusses above the foamboard on the exterior wall. The sheets must extend up 24” or to within 2” of the roof sheathing (whichever is shorter). Seal all joints and gaps with Weathermate tape. This baffle diverts the wind up and over the insulation and also allows ventilation of the underside of the roof.

10.5. INSTALLING BLOCKING

10.5.1. Safety Instruction

1. ALL blocking in stud bays MUST be installed by either hand nailing using 16d nails or secured using 3” drywall screws.

WARNING: Using Paslode nailers to install this blocking is dangerous as an improperly aimed nailer can fire a nail that misses or passes through the wood and potentially strikes a fellow worker.

10.5.2. Blocking For Handicap Grab-Rail

1. Grab-rail blocking must be installed adjacent to the shower and toilet with the top of the blocking 36” above the floor. Install the blocking between all studs that will NOT be covered by cabinets or the shower stall.
2. First, install the 2x6 blocking in a corner stud bay by nailing through the open stud bay into the blocking with three 16d nails. Secure the other end of the blocking to the corner stud by toenailing two 16d nails through the top and bottom of the blocking into the corner stud. Successively install blocking into the adjacent stud bays by first nailing with three 16d nails through the open stud bay into the end of the blocking. Then, attach the opposite, common end, of the blocking by toenailing two 16d nails through the stud into the top and bottom of the blocking.

10.5.3. Blocking For Mirror

1. Blocking for the bathroom mirror must be installed above the vanity area (see House Plan). This will provide solid backing for mounting the mirror clip hardware positioned along the bottom and the top of the mirror.
2. Install 2x6 blocking between all studs where the vanity will be installed. Position the tops of the blocking at 40” and 76” from the floor.

10.5.4. Blocking For Linen Cabinet and Toilet Paper Holder

1. Install 2x6 blocking along the back and one side of where the linen cabinet will be located. Position the top edges of the blocking 60" above the floor.
2. Blocking for the toilet paper holder must be installed in the wall next to the toilet. Install a piece of 2x6 blocking covering a 12" span centered 30" from the wall behind the toilet and positioned so the top edge of the blocking is 26" above the floor.

10.5.5. Blocking For Sheetrock

1. Blocking for sheetrock must be installed in three areas within the house: 1) Along the top plates of walls parallel to trusses for ceiling rock; 2) at the end of all interior walls where they intersect with an **exterior** wall; and, 3) at the end of all interior walls where they intersect with another **interior** wall.
2. Inspect the tops of all walls for areas where blocking may be needed for ceiling rock (see Figure 10-3). For interior walls that are greater than 6" from a truss, make sure that blocking extends at least 1" beyond both ends and sides of any interior wall top plates. Blocking should be continuous at the top of each wall where required.

NOTE: Blocking is only required on one side of the top of interior walls that are within 6" of a truss.

3. Use scrap 2x6, side-by-side 2x4's, 3/4" OSB, or two layers of 1/2" OSB. Nail the pieces to the top of the wall with 16d nails.

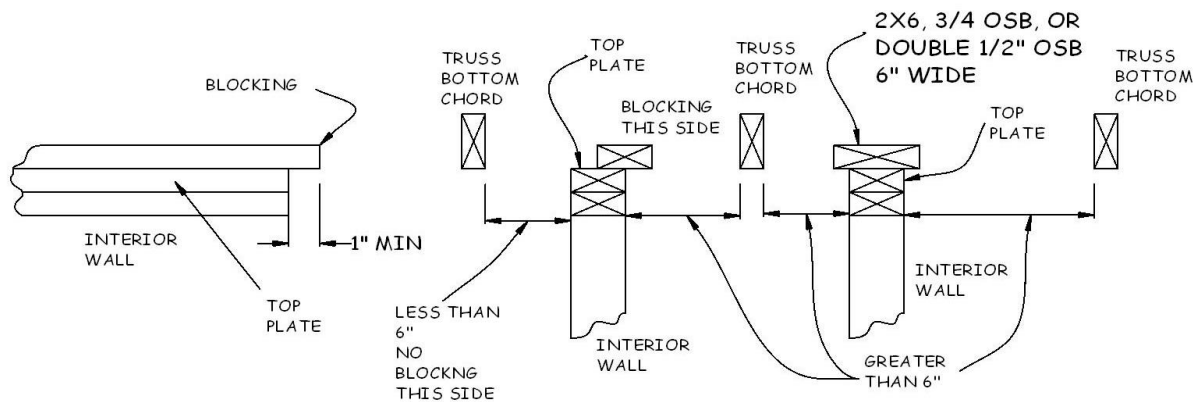

Figure 10-3. Blocking For Ceiling Rock.

4. Install two 43" long pieces of 3/4" OSB blocking at the ends of any interior walls that intersect an exterior wall – one above the 2x4 ladder block and one below the 2x4 ladder block. The blocking must extend at least 2" beyond the edges of the stud, so cut the OSB to a width of 5 1/2" or 7 1/2" for a 2x4 wall and 7 1/2" or 9 1/2" for a

2x6 wall. Pre-drill four pairs of 3/16" holes, spaced evenly vertically, through the stud (about 1/2"-3/4" in from each edge). To attach the blocking, hold the piece of OSB in place, making sure it is tight (no gaps) to the outside of the end stud (use a clamp, if necessary). Attach the OSB blocking by screwing 2" screws through the holes in the 2x4 into the OSB, turning the screw until it is buried about 1/4" into the stud. If there is access to drive screws from the blocking side of stud, it is acceptable to use two layers of 1/2" OSB. See Figure 10-4.

5. Where an interior wall intersects an interior wall (See Figure 10-4), install blocking using 2x4's, 3/4" OSB, or two layers of 1/2" OSB. Secure the blocking to the end stud using 16d nails for 2x4 blocking and 2" screws for OSB blocking.
6. Install blocking around the perimeter of the stair landing platform to support the bottom of the wall sheet rock, since there is no bottom plate present at that level. Nail or screw 2x4s between the wall studs with the bottom at the level of the landing floor deck.

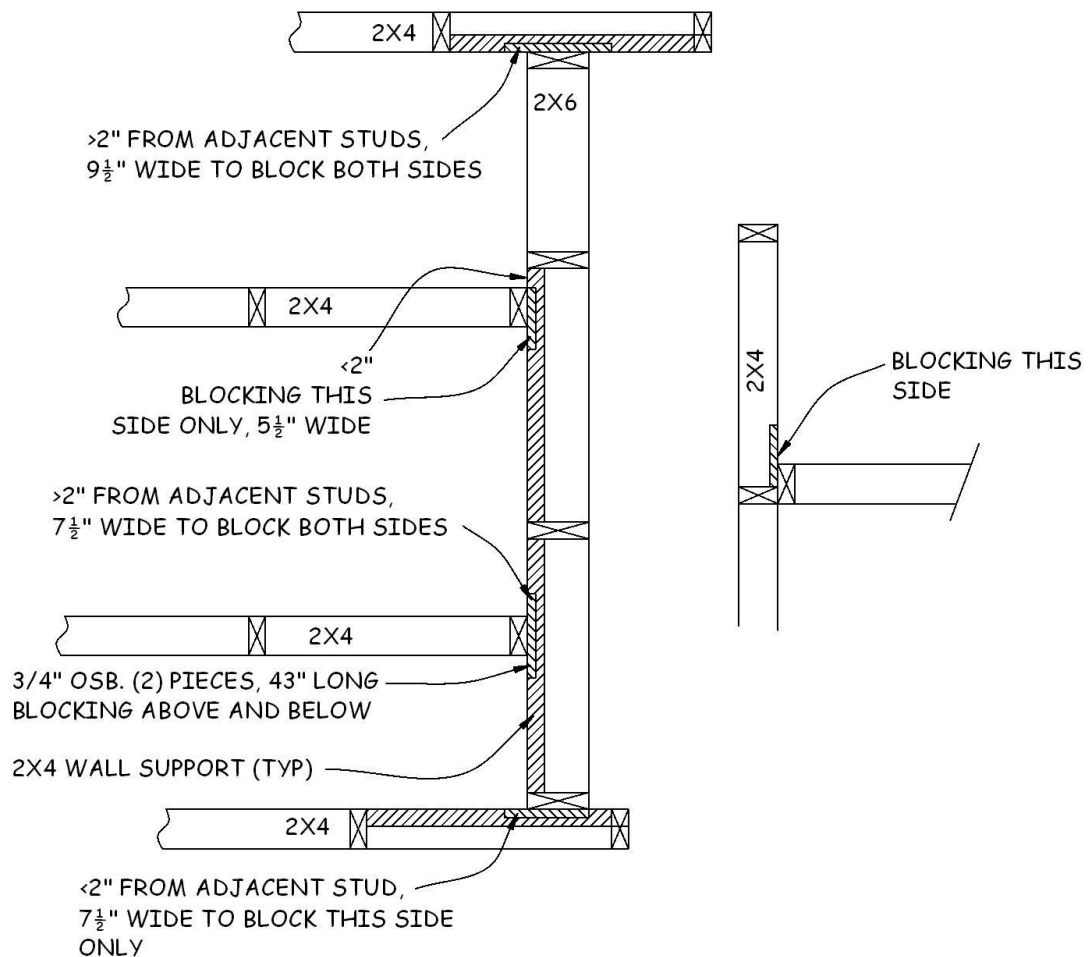

Figure 10-4. Blocking For Wall Rock.

10.5.6. Blocking For Stairskirt

1. Use a piece of 2x6 or two pieces of 2x4 at the bottom of the stairs and one piece of 2x4 at the top of the stairs to install blocking for the stairskirt (see Figure 10-5.). At the bottom of the stairs, block from the end of the stringer to at least 5" past that point. At the top of the stairs, block where the $\frac{3}{4}$ " subfloor ends at the stair, at least 3" both above and beyond the subfloor.

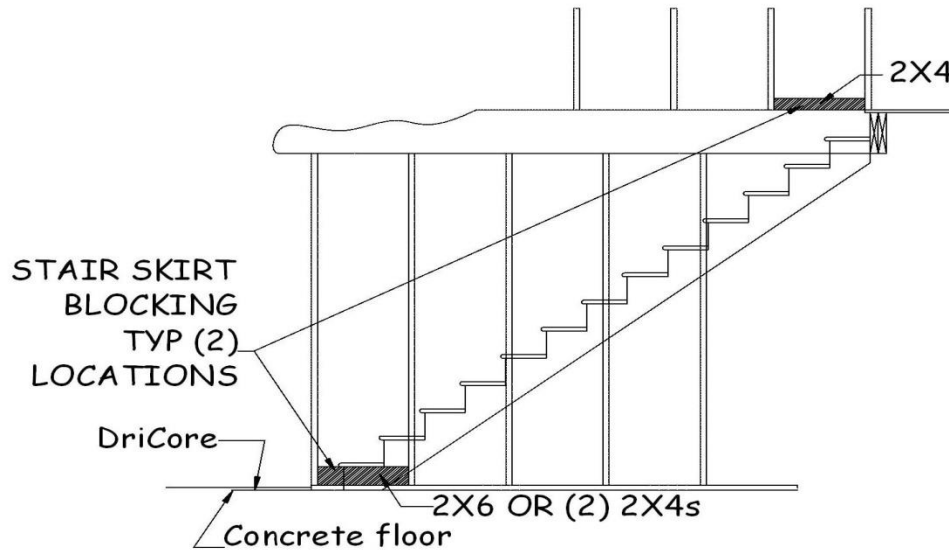

Figure 10-5. Blocking for Stairskirt.

10.5.7. Blocking For Stair Handrail

1. Straight stairways will have handrails (and require blocking) on the wall opposite the angled wall. Stairs with landing will have the handrail on the wall opposite the lower section of stairs, or the "outside" of the stairwell. The section below the landing will also require blocking.
2. The handrail bracket bottom screws will be mounted approximately 31" above a line that is defined by the nose of the treads. This will place the top of the handrail between the required 34" and 36" above the nose of the treads. To provide some latitude in the placement, measure up 32" from the decking, vertically at the edge of the floor deck, and mark the wall at that height. At the bottom of the stairs, again measure up 32" from the nose of the bottom stair tread. Snap a chalk line between the top and bottom marks. The blocking must be installed so that the top corner toward the top of the stairs is even with the line, and the bottom corner toward the bottom of the stairs is even with the line. (See Figure 10-6.)
3. For blocking, use a combination of scrap 2x12's, 2x10's or 2 x6's to equal a minimum height of 18" (see Figure 10-6). The extra height helps to ensure that handrail brackets will be secured to the blocking after drywall is installed.

4. Install blocking between the bottom two treads, the middle two treads, and the top two treads. Find the location of the middle blocking by measuring the length of the chalk line made in Step 2, then dividing that in half. For stairs below a landing, omit the middle blocking.

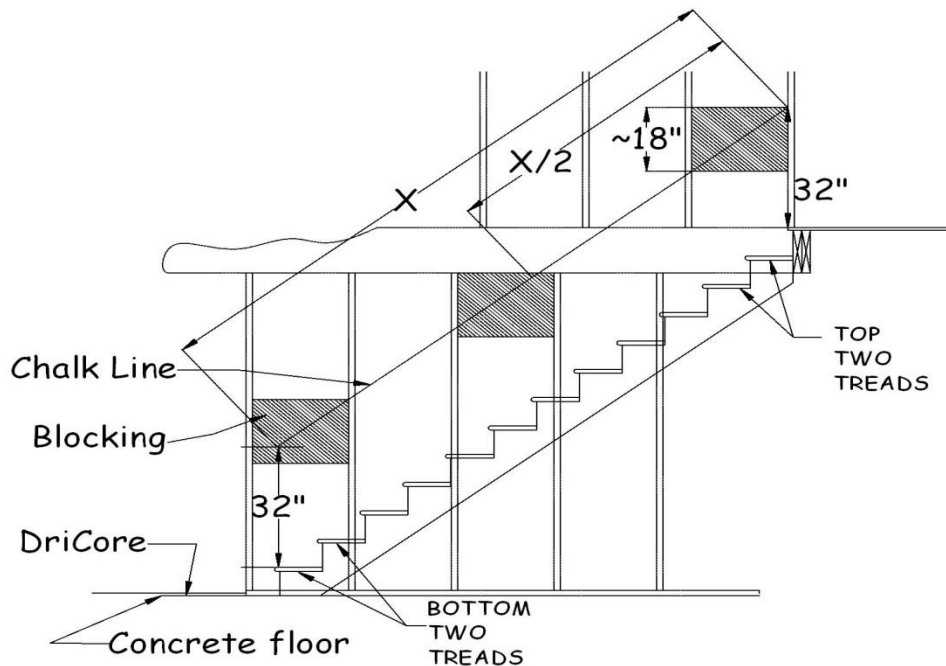

Figure 10-6. Blocking For Handrail.

5. Mark location of the blocks on the temporary stair treads to facilitate finding the blocks after plastering.

10.5.8. Blocking For Closet Pole Hangers

1. In each corner of every closet that will receive a closet pole, install a scrap piece of 2x4, at least 16" long, so there is something to attach the hanger to.
2. At the corner, make a mark 70" off the floor. Hold the piece vertically, place the top at that mark, and nail it flush to the 2x4 closet stud.

10.5.9. Blocking for Cold Air Returns

1. Blocking is required next to cold air returns to provide support for the register installation screw opposite the stud side.
2. Install blocking extending between each cold air return and the adjacent stud. Use a 9" high stack of six 2x4s on top of the bottom plate as shown in Figure 10-7.



Figure 10-7. Cold Air Return Blocking.

10.5.10. Blocking for Large Windows

1. Window openings 6' or greater need additional "squash" blocking to support the longer expanse of the opening.
2. Cut four 2"x6"x9½" pieces. Create two blocks by nailing pairs of these pieces together. Position the blocks between the sill plate and the bottom of the decking under the K/J/J on each side of the window with the face of each block against the 2" foamboard. The blocks should fit tightly but can be further secured by toenailing 8d nails through the blocks into the sill plate.